

Sit and surf.

# L-Shaped Desk

Willow Place Collection | **Model 5433812**

**NOTE:** THIS INSTRUCTION BOOKLET CONTAINS **IMPORTANT** SAFETY INFORMATION.

PLEASE READ AND KEEP FOR FUTURE REFERENCE.

English pg 1-37

Lot # **592357**

02/17/23

Purchased: \_\_\_\_\_

Part Identification	2-3
Hardware Identification	4-5
Hardware Usage Guide	6
Assembly Steps	7-37
Français	38-42
Español	43-47
Safety	48-50
Warranty	51

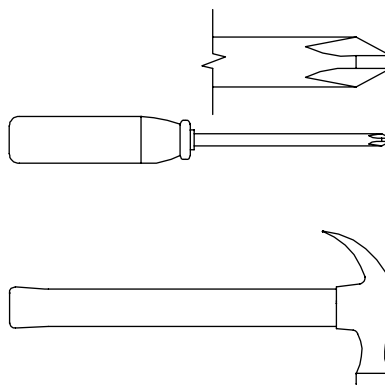

No. 2 Phillips Screwdriver  
Tip Shown Actual Size

Hammer  
Not actual size 😊

## Part Identification

⚠ While not all parts are labeled, some of the parts will have a label or an inked letter on the edge to help distinguish similar parts from each other. Use this part identification to help identify similar parts.

A2	RIGHT END (1)	D109	SMALL DRAWER BACK (1)	M	ADJUSTABLE SHELF (1)
B2	LEFT END (1)	D707	DRAWER BOTTOM (2)	N	BRACE (1)
C	SHELF (1)	E	BOTTOM (2)	O2	SMALL TOP (1)
D2	LARGE MODESTY PANEL (1)	F2	SMALL MODESTY PANEL (1)	P2	RIGHT UPRIGHT (1)
D28	LARGE RIGHT DRAWER SIDE (1)	G	SMALL DRAWER FRONT (1)	Q2	LEFT UPRIGHT (1)
D29	LARGE LEFT DRAWER SIDE (1)	H	LARGE DRAWER FRONT (1)	R2	LARGE TOP (1)
D78	LARGE DRAWER BACK (1)	J2	RIGHT CORNER UPRIGHT (1)	S	FOOT (8)
D107	SMALL RIGHT DRAWER SIDE (1)	K	LEFT CORNER UPRIGHT (1)		
D108	SMALL LEFT DRAWER SIDE (1)	L2	BACK (2)		

# Part Identification

Now you know  
our ABCs.

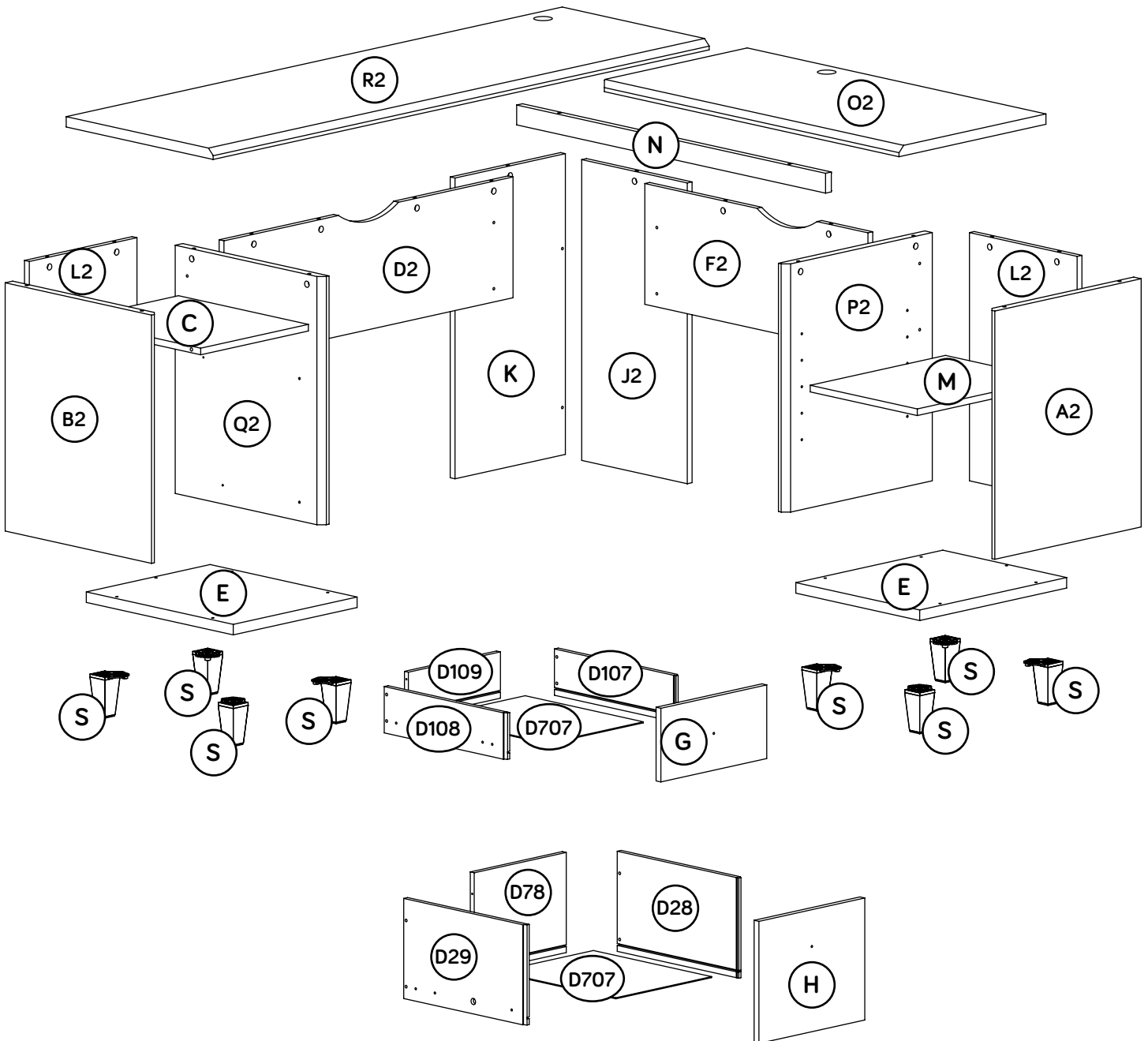

# Hardware Identification

↑ Screws are shown actual size. You may receive extra hardware with your unit.

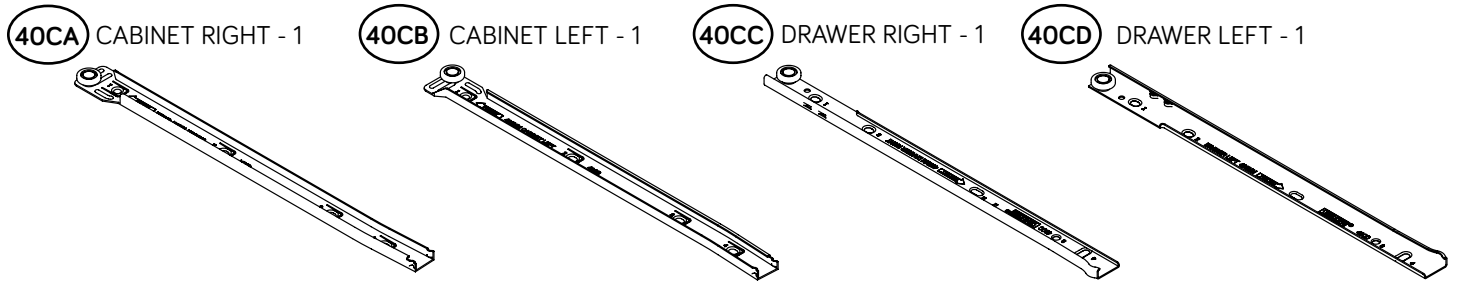

(EXTENSION SET SHOWN SEPARATED)

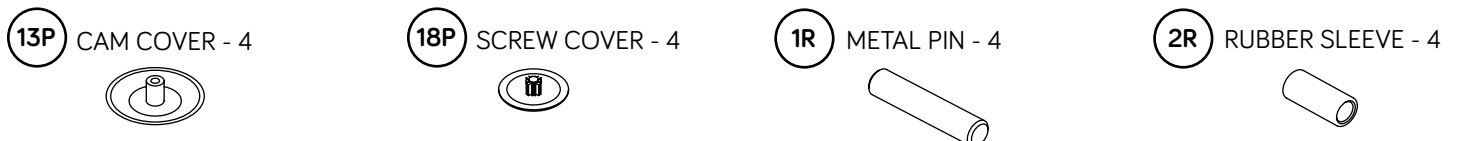
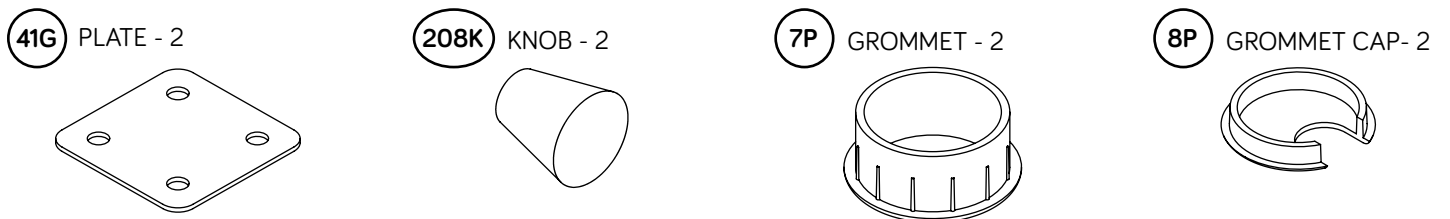
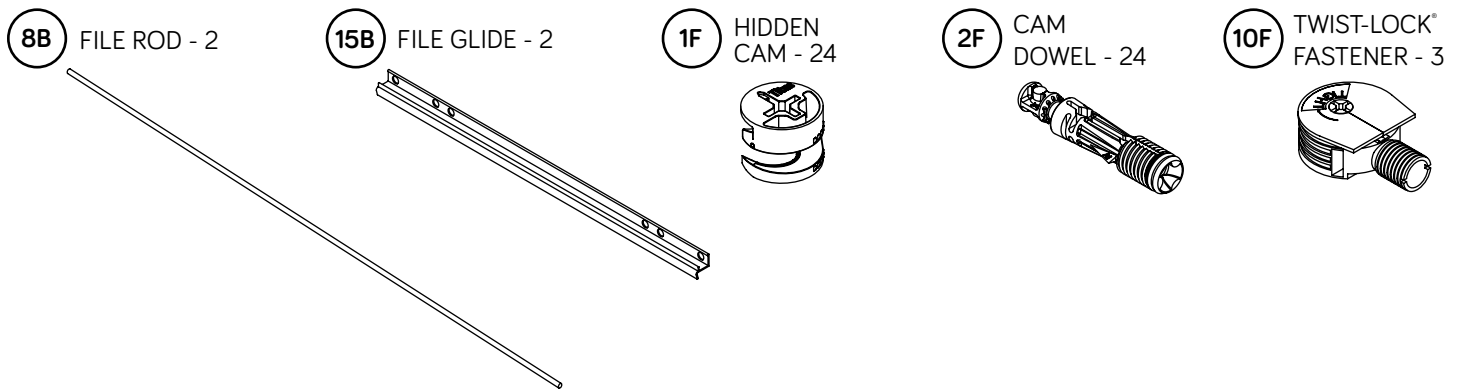
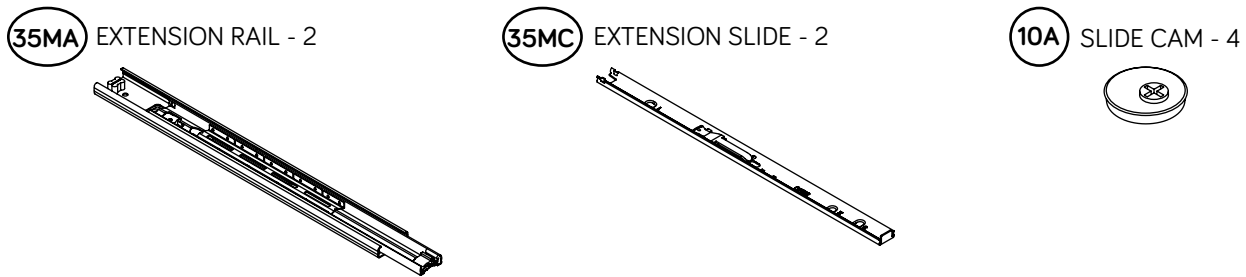

# Hardware Identification

† Screws are shown actual size. You may receive extra hardware with your unit.

**1S** BLACK 9/16" LARGE HEAD SCREW - 8

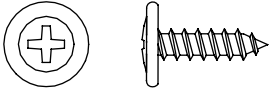

**3S** GOLD 5/16" FLAT HEAD SCREW - 16



**10S** SILVER 1-1/8" FLAT HEAD SCREW - 4

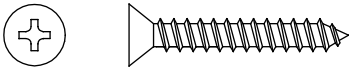

**30S** BLACK 1-9/16" FLAT HEAD SCREW - 8

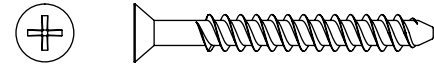

**37S** BLACK 7/8" MACHINE SCREW - 2

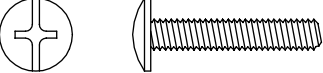

**85S** BLACK 3/4" PAN HEAD SCREW - 8

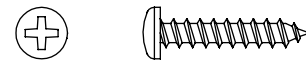

**113S** BLACK 1-15/16" FLAT HEAD SCREW - 2

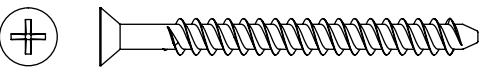

**144S** BLACK 15/16" SHOULDER SCREW - 32

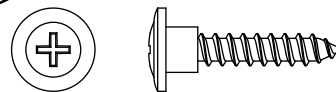

**146S** BLACK 2-3/8" FLAT HEAD SCREW - 14

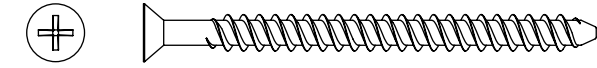

# Hardware Usage Guide

## HOW TO USE A HIDDEN CAM & CAM DOWEL

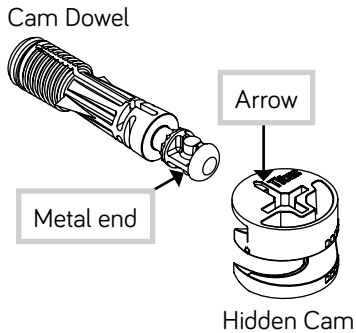

2. Insert the metal end of the CAM DOWEL into the HIDDEN CAM.

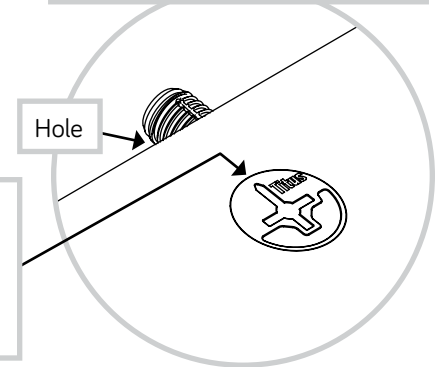

1. Push a HIDDEN CAM into the part. The arrow in the HIDDEN CAM must point toward the hole in the edge of the board.

3.

**⚠ Caution**  
Risk of damage or injury. HIDDEN CAMS must be completely tightened. HIDDEN CAMS that are not completely tightened may loosen, and parts may separate. To completely tighten:

**Start**

Arrow

**Tighten**

Maximum 210 degrees

Minimum 190 degrees

Arrow

## HOW TO USE A TWIST-LOCK® FASTENER

1. Push a TWIST-LOCK® FASTENER into the large hole in the part.

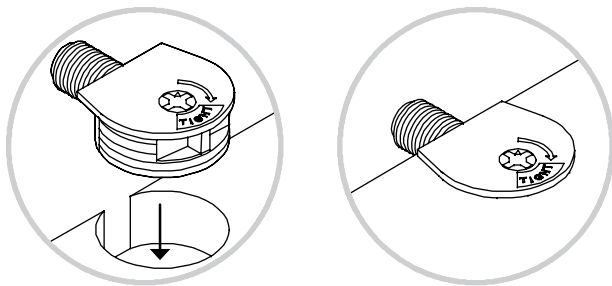

2. 1. Insert the dowel end of the FASTENER into the hole of the adjoining part.  
**NOTE:** The dowel end of the FASTENER must remain fully inserted in the hole of the adjoining part while locking the FASTENER.  
2. Tighten the FASTENER with a Phillips screwdriver as tight as possible.

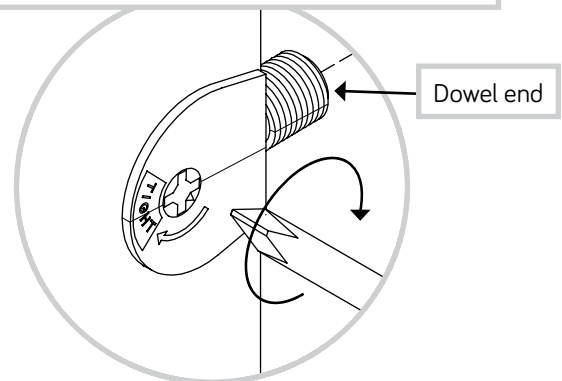

# Step 1

- ✚ Assemble your unit on a carpeted floor or on the empty carton to avoid scratching your unit or the floor.
- ✚ Push two HIDDEN CAMS (1F) into the CORNER UPRIGHTS (J2 and K). Then, insert the metal end of a CAM DOWEL (2F) into each HIDDEN CAM.

Do not tighten the HIDDEN CAMS in this step.

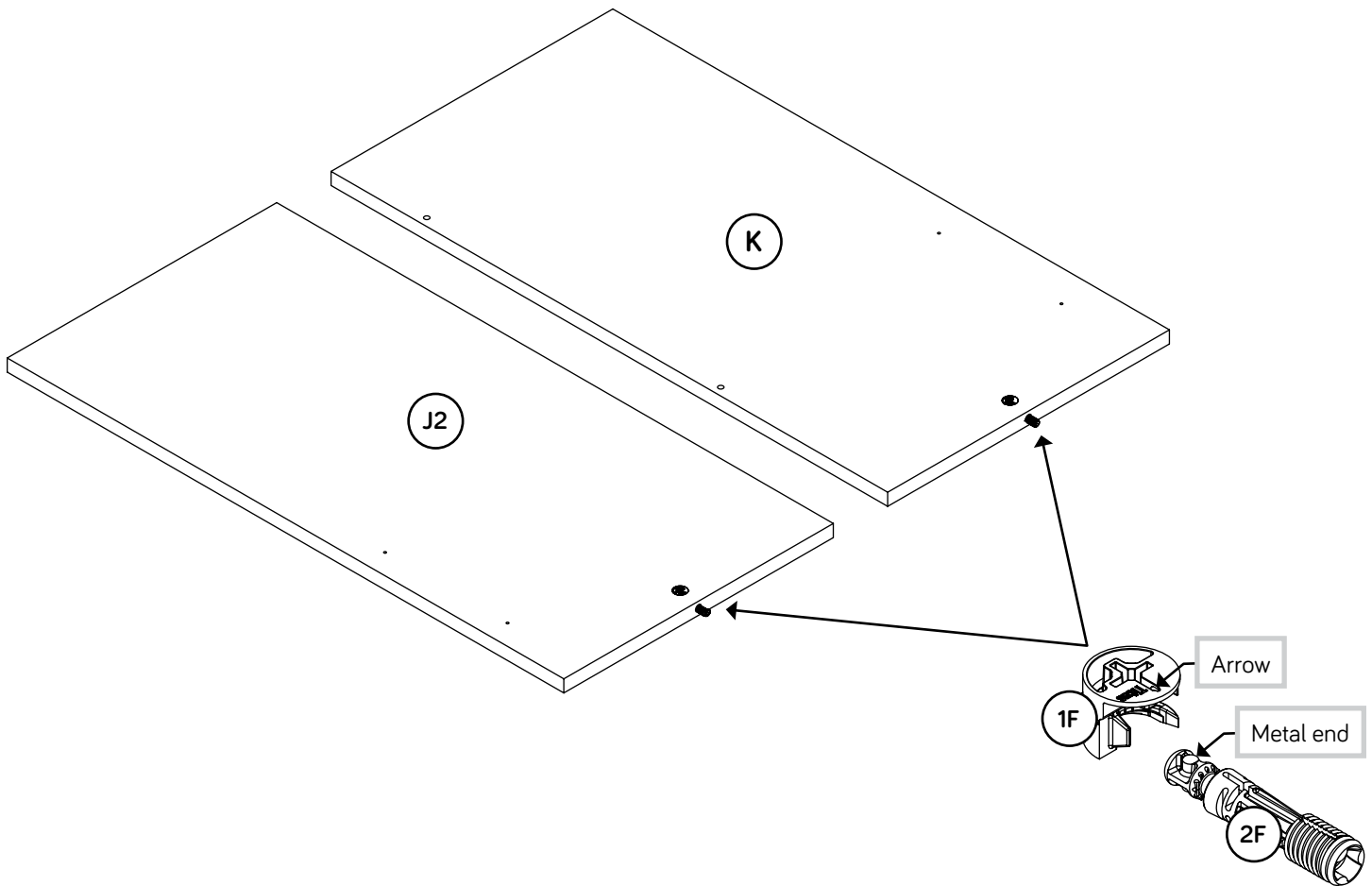

## Step 2

- ⚡ Fasten the LEFT CORNER UPRIGHT (K) to the RIGHT CORNER UPRIGHT (J2). Use two BLACK 1-15/16" FLAT HEAD SCREWS (113S).

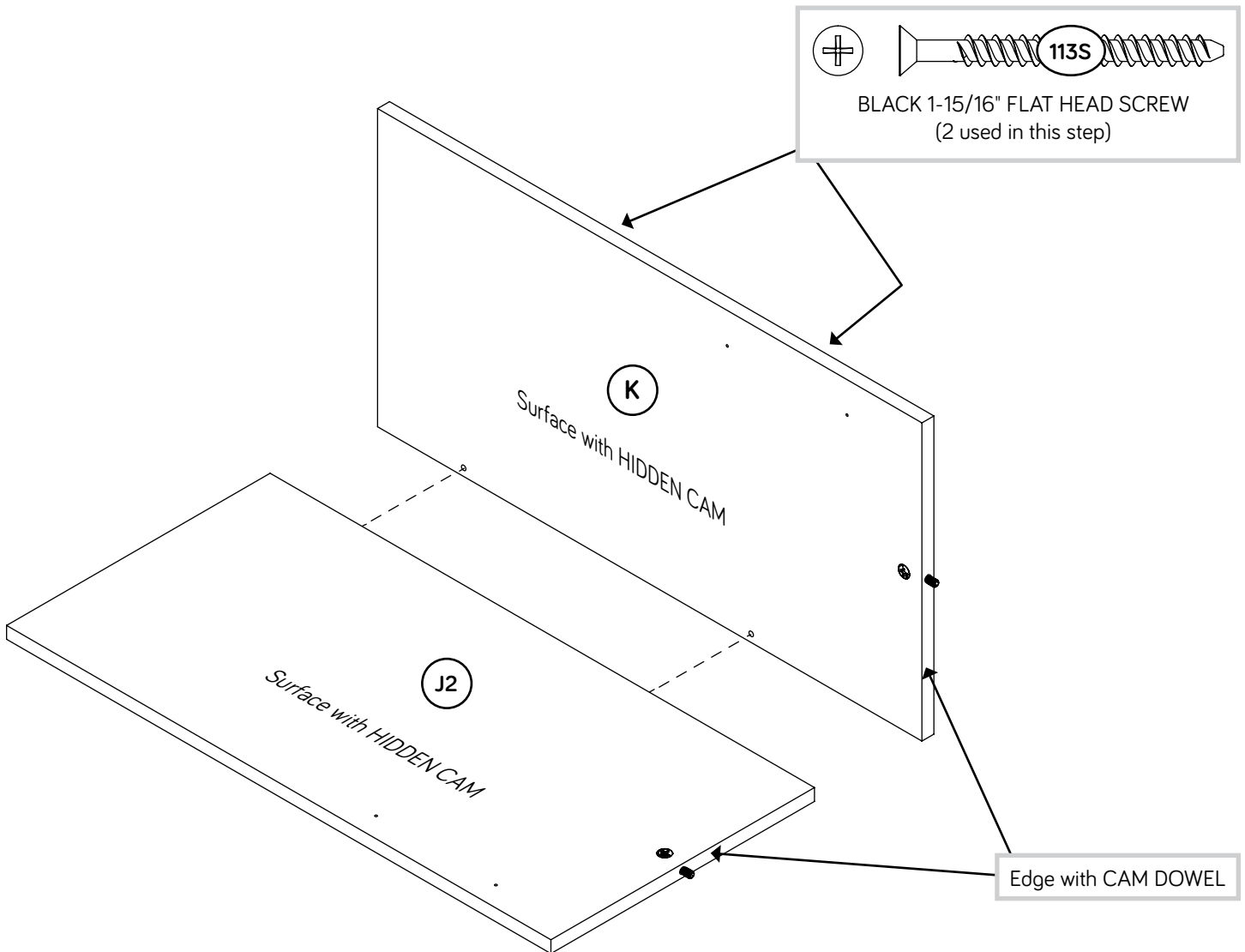

# Step 3

- Fasten the CORNER UPRIGHTS (J2 and K) to the LARGE TOP (R2). Tighten two HIDDEN CAMS.



Some assembly  
(and snacks) required.

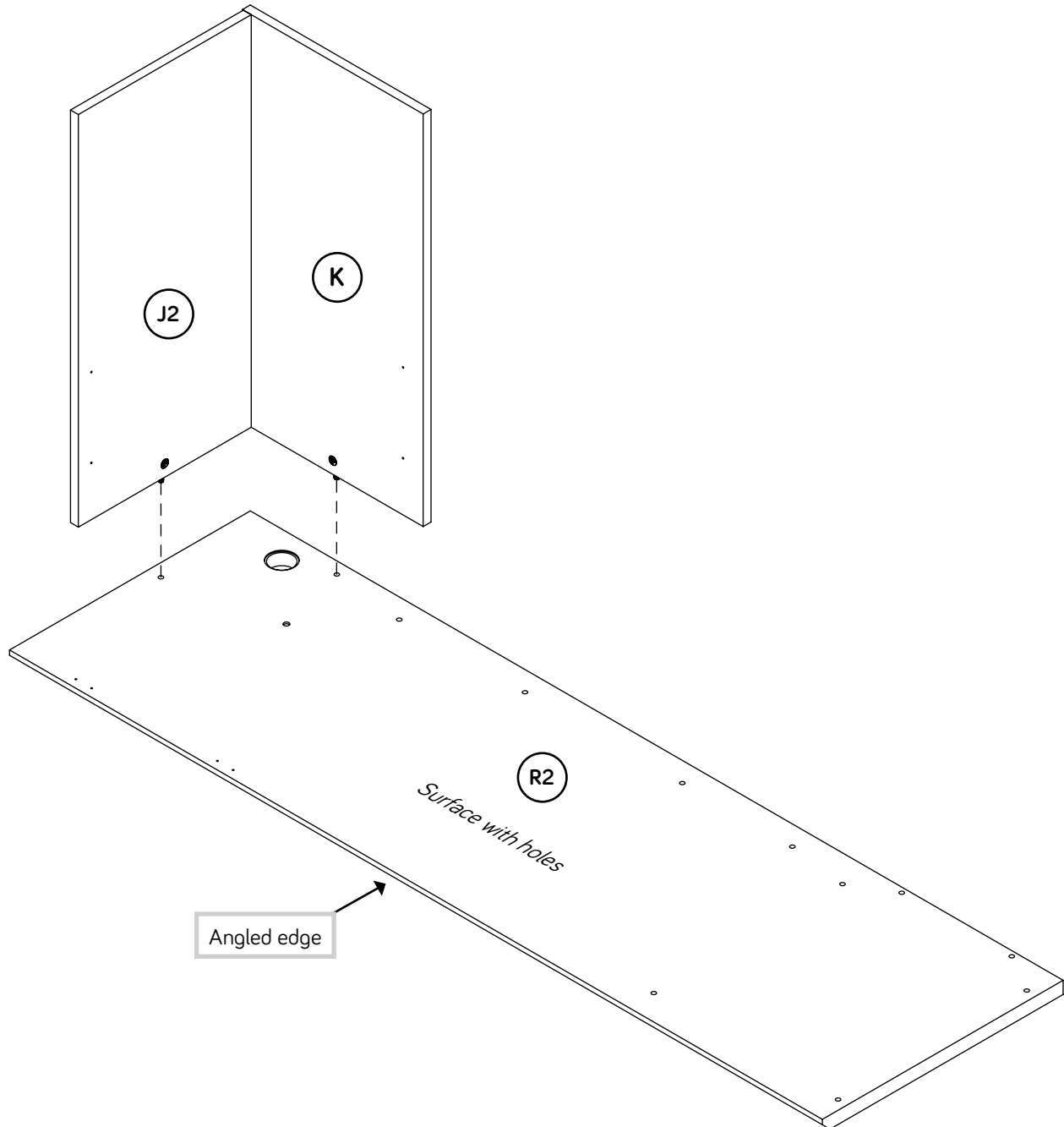

# Step 4

- ✚ Push four HIDDEN CAMS (1F) into the LARGE MODESTY PANEL (D2).  
Then, insert the metal end of a CAM DOWEL (2F) into each HIDDEN CAM.
- ✚ Fasten the LARGE MODESTY PANEL (D2) to the LARGE TOP (R2).  
Tighten four HIDDEN CAMS.
- ✚ Fasten the LARGE MODESTY PANEL (D2) to the LEFT CORNER UPRIGHT (K). Use two SILVER 1-1/8" FLAT HEAD SCREWS (10S).
- ✚ NOTE: You should start each SCREW a few turns before completely tightening any of them.
- ✚ NOTE: Do not overtighten the SCREWS into the CORNER UPRIGHT.

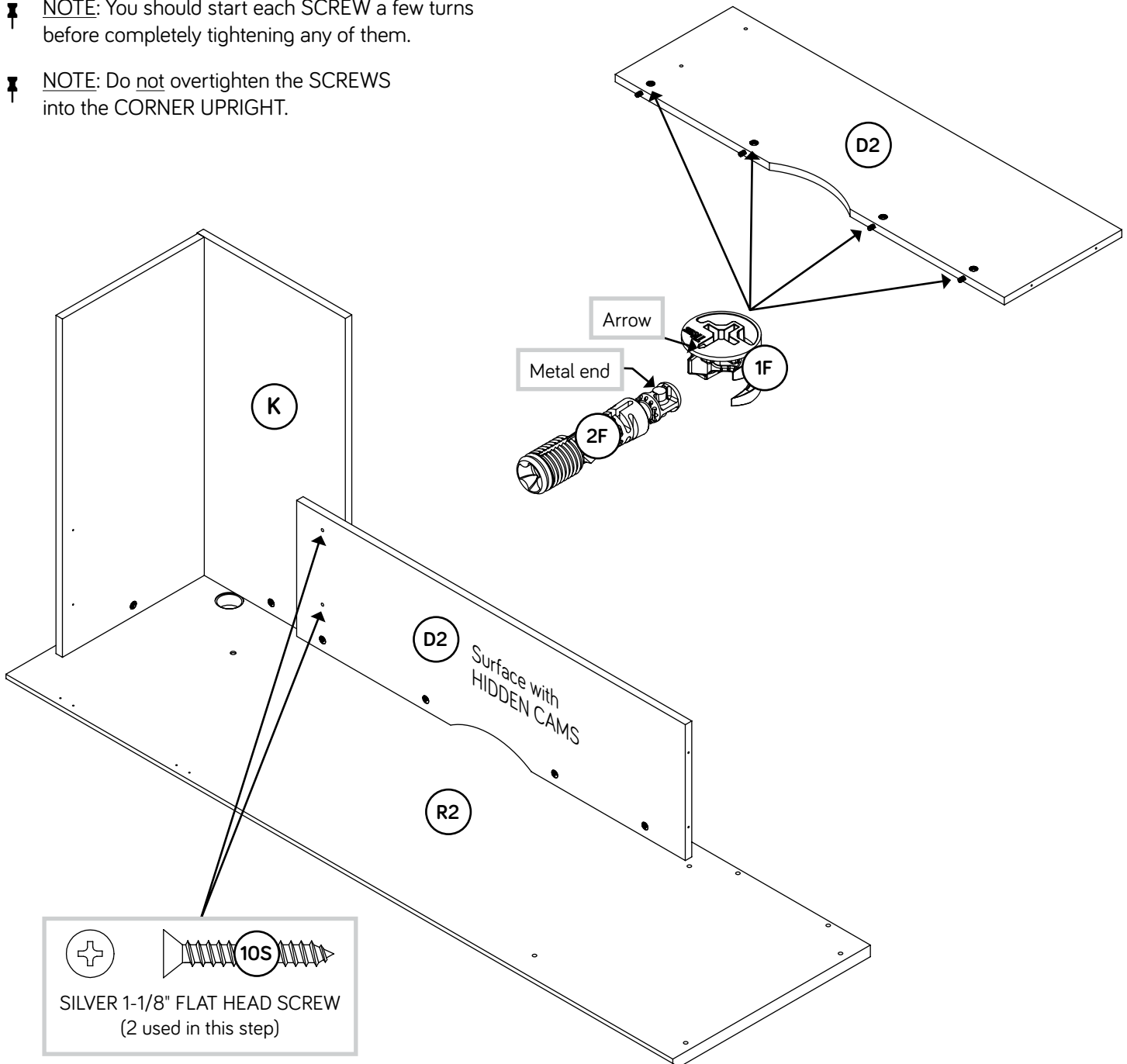

# Step 5

- Fasten the CABINET RIGHT (40CA) to the LEFT UPRIGHT (Q2). Use two GOLD 5/16" FLAT HEAD SCREWS (3S) through holes #1 and #4.

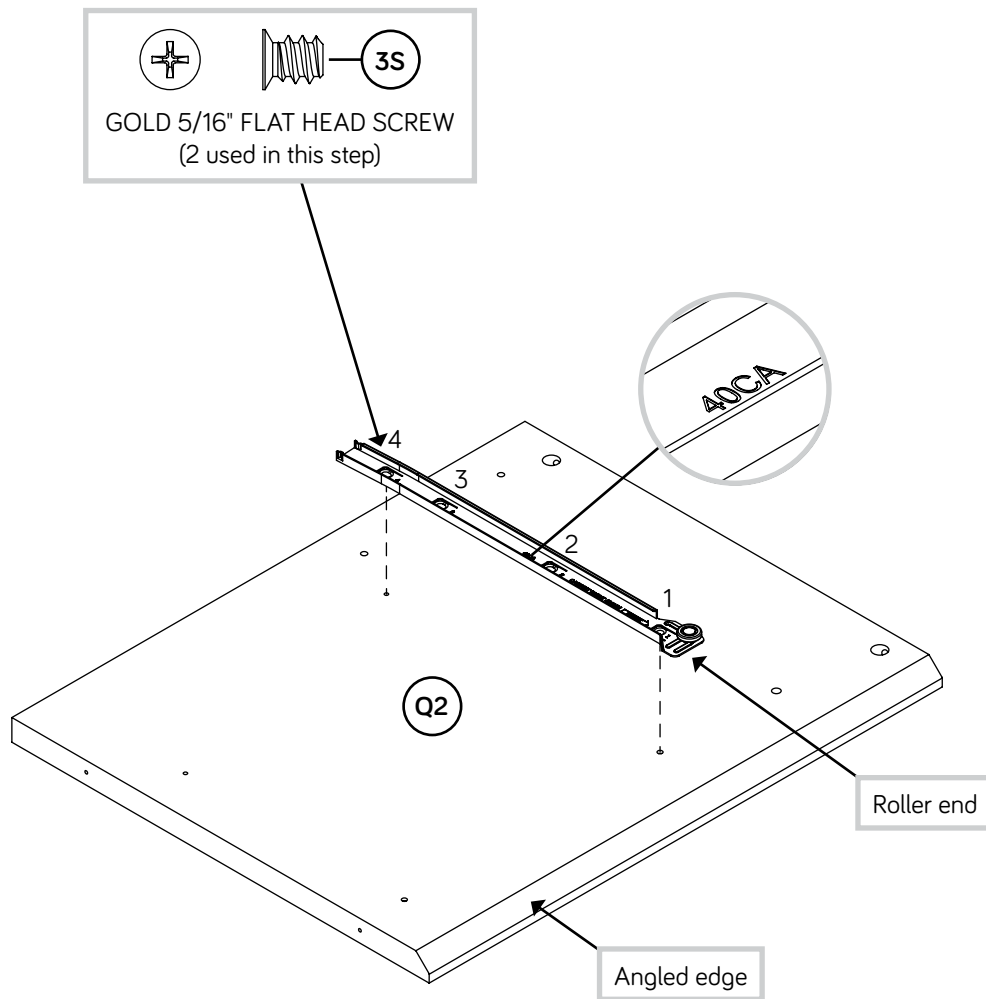

# Step 6

- ✚ Separate the EXTENSION SLIDES (35MC) from the EXTENSION RAILS (35MA) as shown in the upper diagram below. Be prepared, the parts are greasy.
- ✚ Fasten one EXTENSION RAIL (35MA) to the LEFT UPRIGHT (Q2). Use two GOLD 5/16" FLAT HEAD SCREWS (3S) through holes #1 and #3.
- ✚ NOTE: For each EXTENSION RAIL, turn a SCREW into the hole shown in the enlarged diagram. Then, slide the inner cartridge of the EXTENSION RAIL in to find the other hole that lines up with the hole in the UPRIGHT. Turn a SCREW into this hole.
- ✚ NOTE: The EXTENSION SLIDES (35MC) will be used later for the LARGE DRAWER.

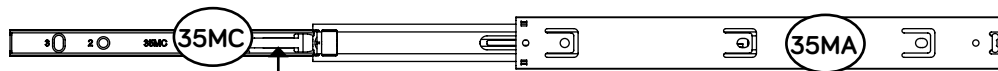

Push the black lever in and pull the SLIDE from the RAIL.

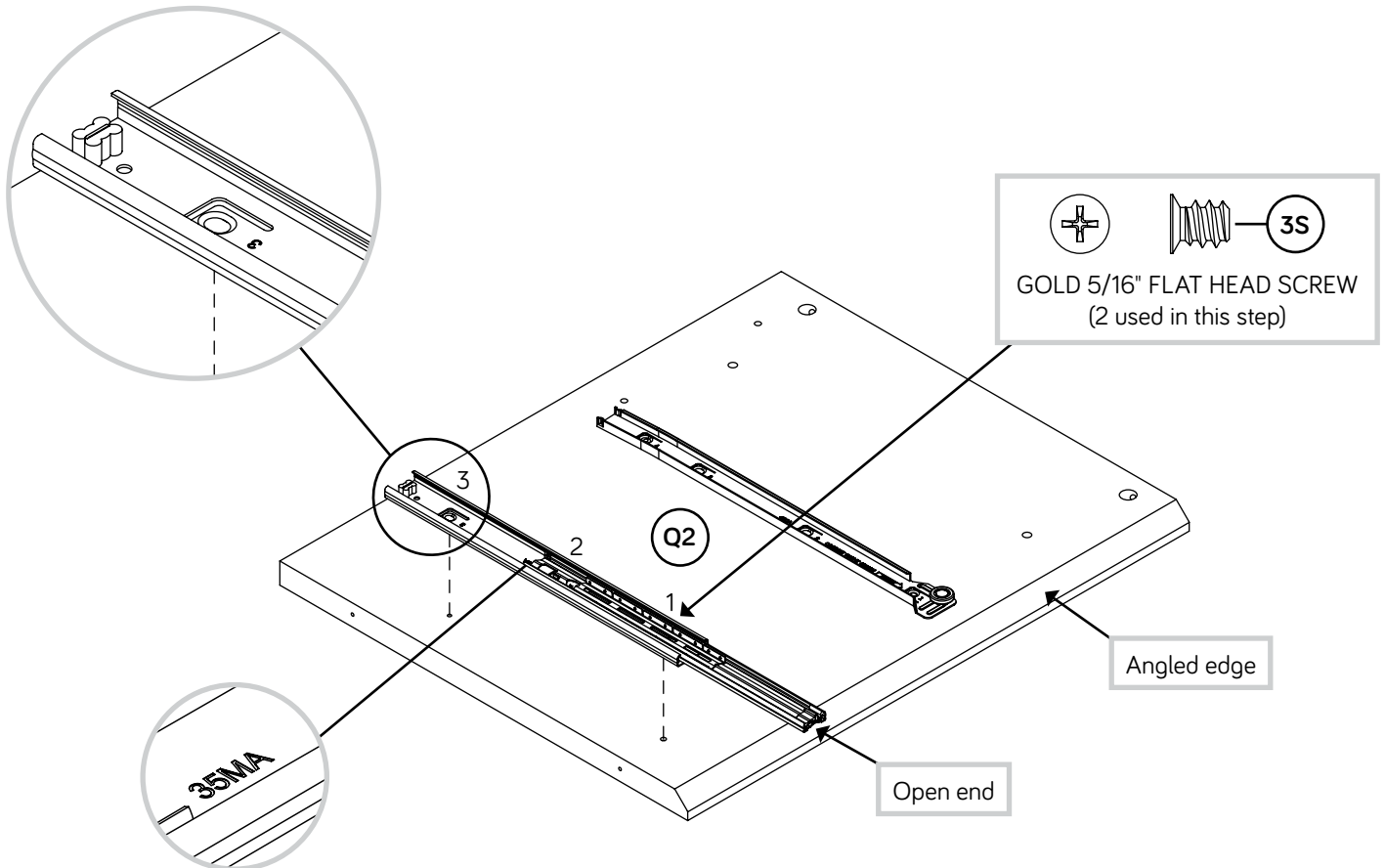

# Step 7

- ✚ Push two HIDDEN CAMS (1F) into the LEFT UPRIGHT (Q2). Then, insert the metal end of a CAM DOWEL (2F) into each HIDDEN CAM.
- ✚ Fasten the LEFT UPRIGHT (Q2) to the LARGE TOP (R2). Tighten two HIDDEN CAMS.
- ✚ Fasten the LEFT UPRIGHT (Q2) to the LARGE MODESTY PANEL (D2). Use two BLACK 2-3/8" FLAT HEAD SCREWS (146S).
- ✚ **NOTE:** You should start each SCREW a few turns before completely tightening any of them.

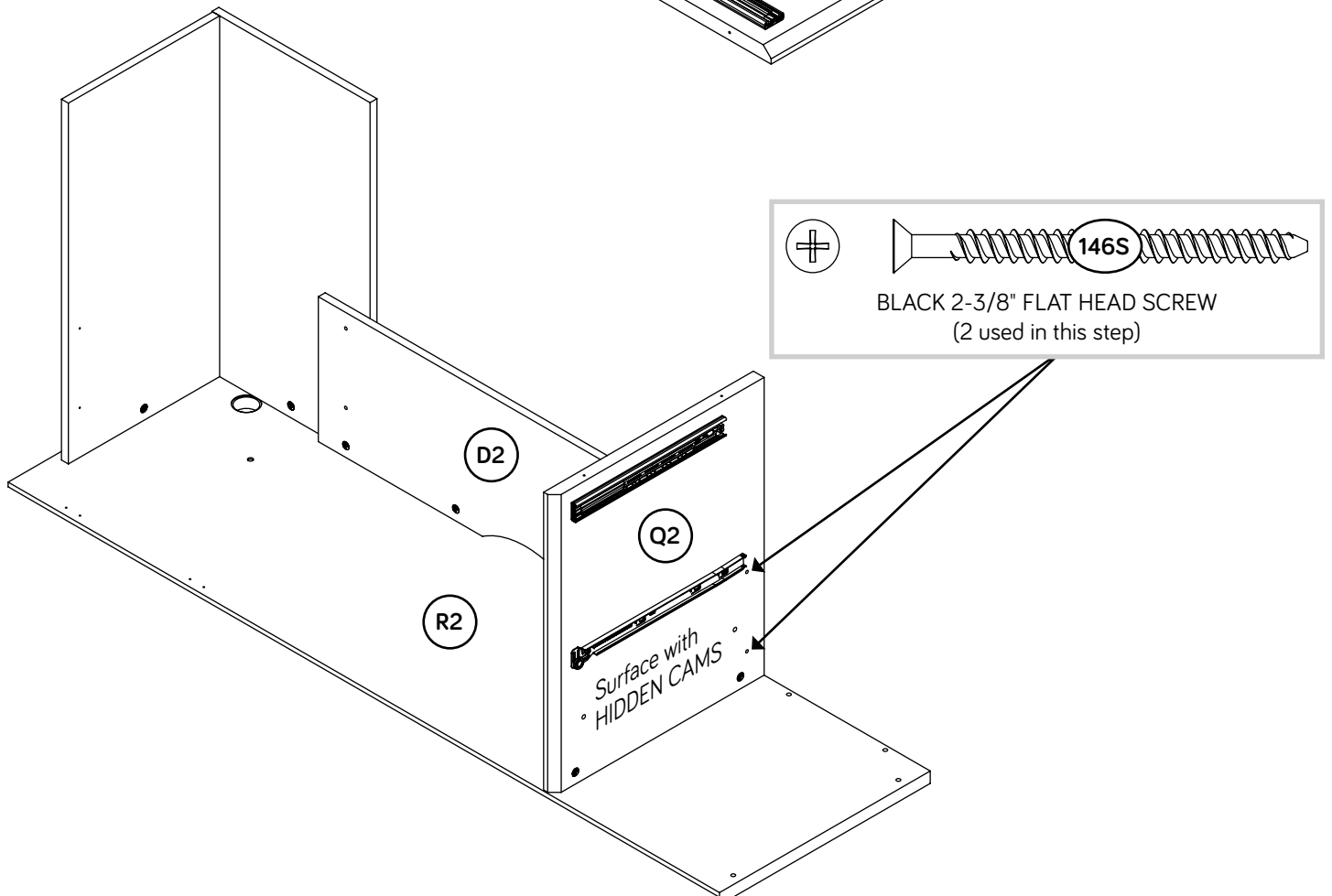
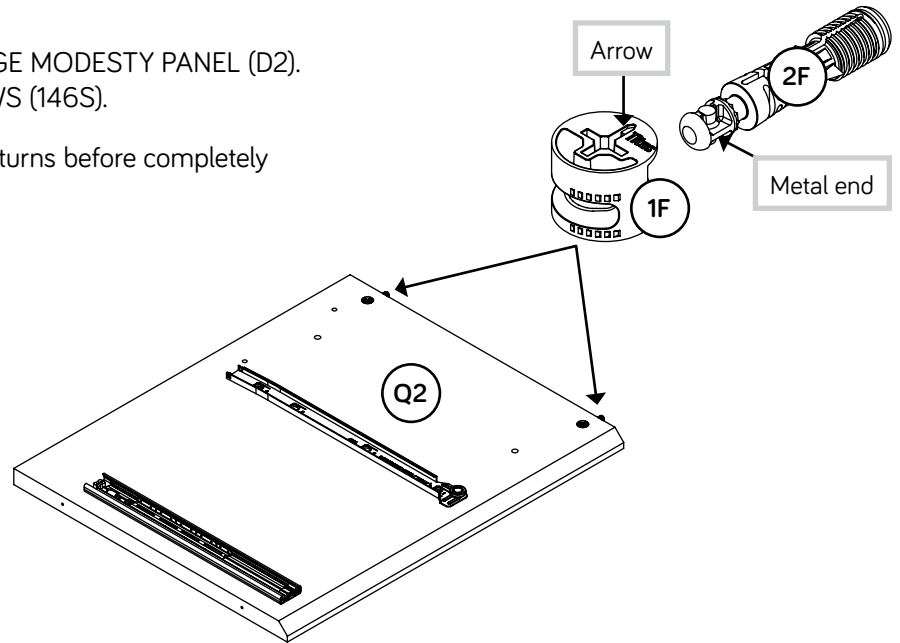

# Step 8

- ✚ Push two HIDDEN CAMS (1F) into one of the BACKS (L2). Then, insert the metal end of a CAM DOWEL (2F) into each HIDDEN CAM.
- ✚ Fasten the BACK (L2) to the LARGE TOP (R2). Tighten two HIDDEN CAMS.

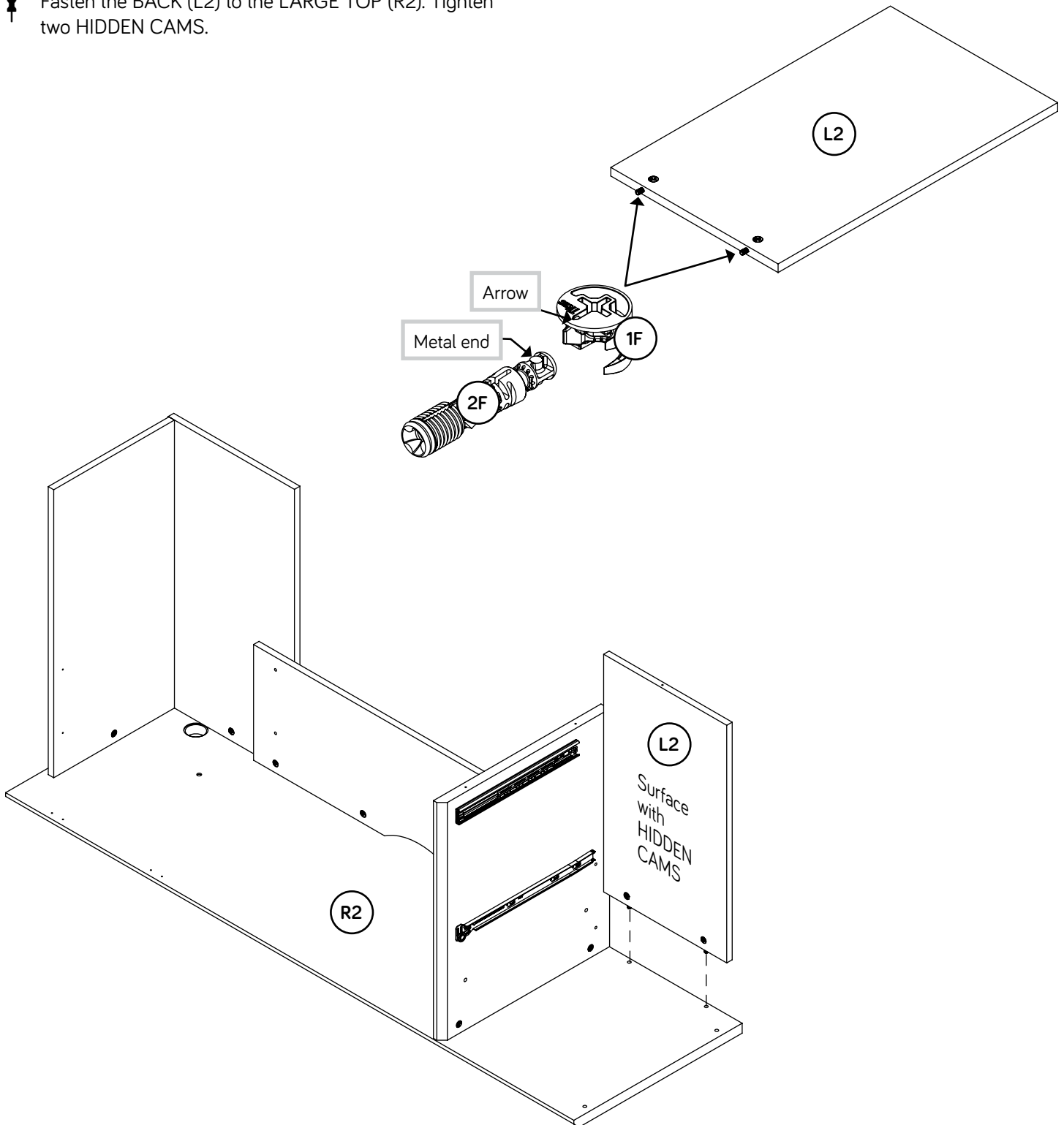

# Step 9

- ✚ Push four HIDDEN CAMS (1F) into the SHELF (C). Then, insert the metal end of a CAM DOWEL (2F) into each HIDDEN CAM.
- ✚ Fasten the SHELF (C) to the LEFT UPRIGHT (Q2). Tighten two HIDDEN CAMS.

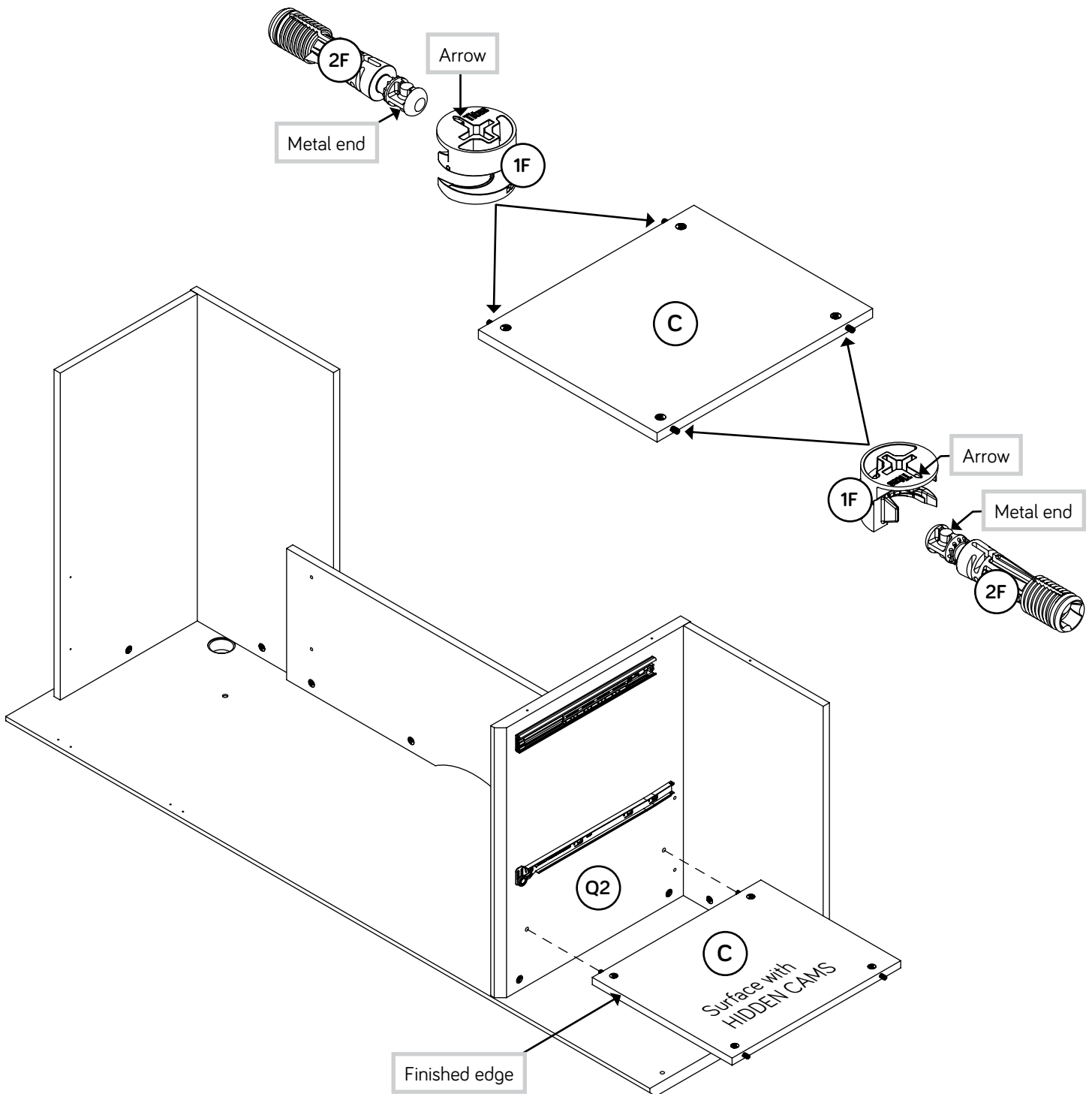

# Step 10

- Fasten the CABINET LEFT (40CB) to the LEFT END (B2). Use two GOLD 5/16" FLAT HEAD SCREWS (3S) through holes #1 and #4.

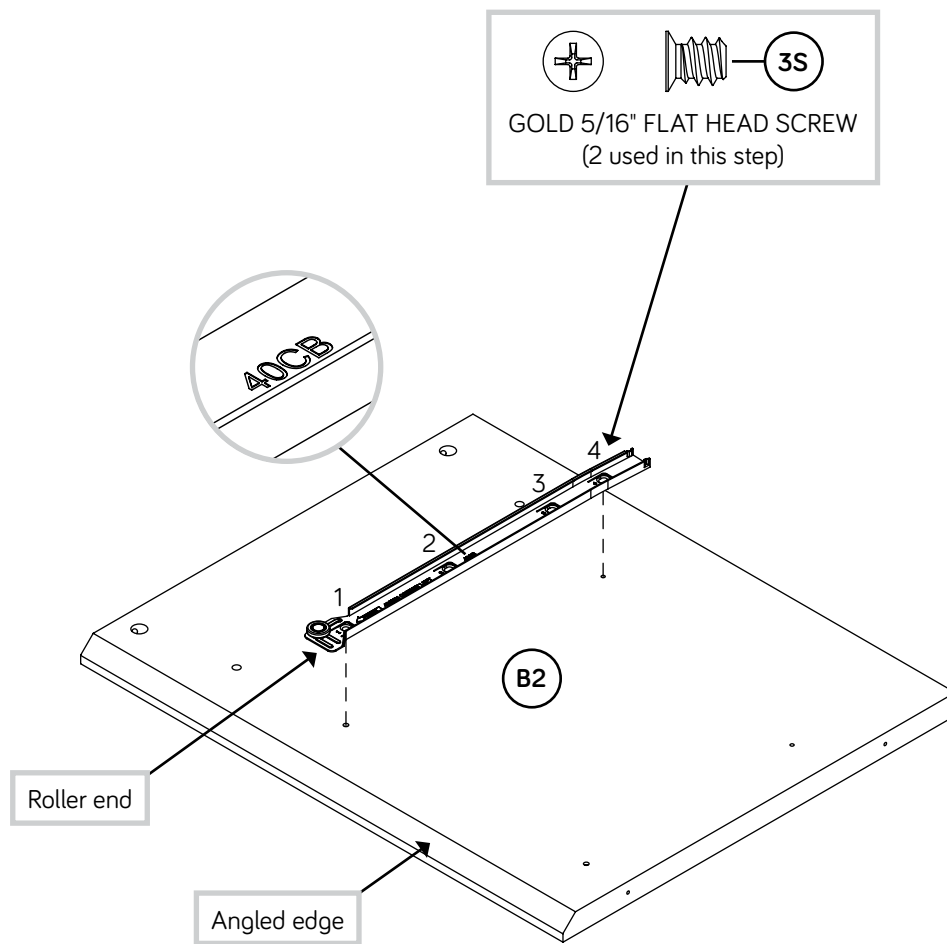

# Step 11

Fasten the remaining EXTENSION RAIL (35MA) to the LEFT END (B2). Use two GOLD 5/16" FLAT HEAD SCREWS (3S) through holes #1 and #3.

**NOTE:** For each EXTENSION RAIL, turn a SCREW into the hole shown in the enlarged diagram. Then, slide the inner cartridge of the EXTENSION RAIL in to find the other hole that lines up with the hole in the END. Turn a SCREW into this hole.

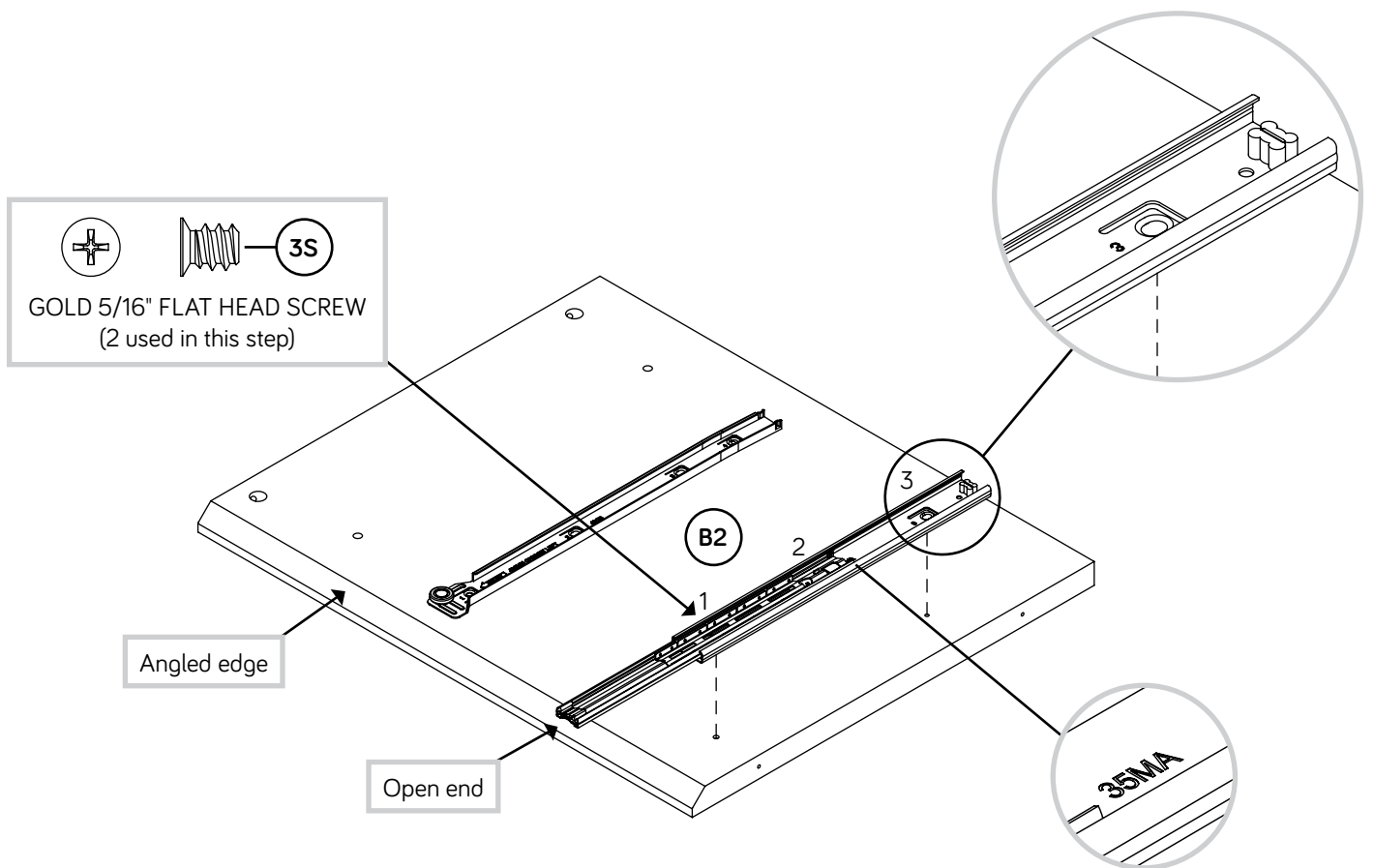

# Step 12

- ✚ Push two HIDDEN CAMS (1F) into the LEFT END (B2). Then, insert the metal end of a CAM DOWEL (2F) into each HIDDEN CAM.
- ✚ Fasten the LEFT END (B2) to the SHELF (C) and LARGE TOP (R2). Tighten four HIDDEN CAMS.



Just think. The sooner you do this, the sooner you do something else.

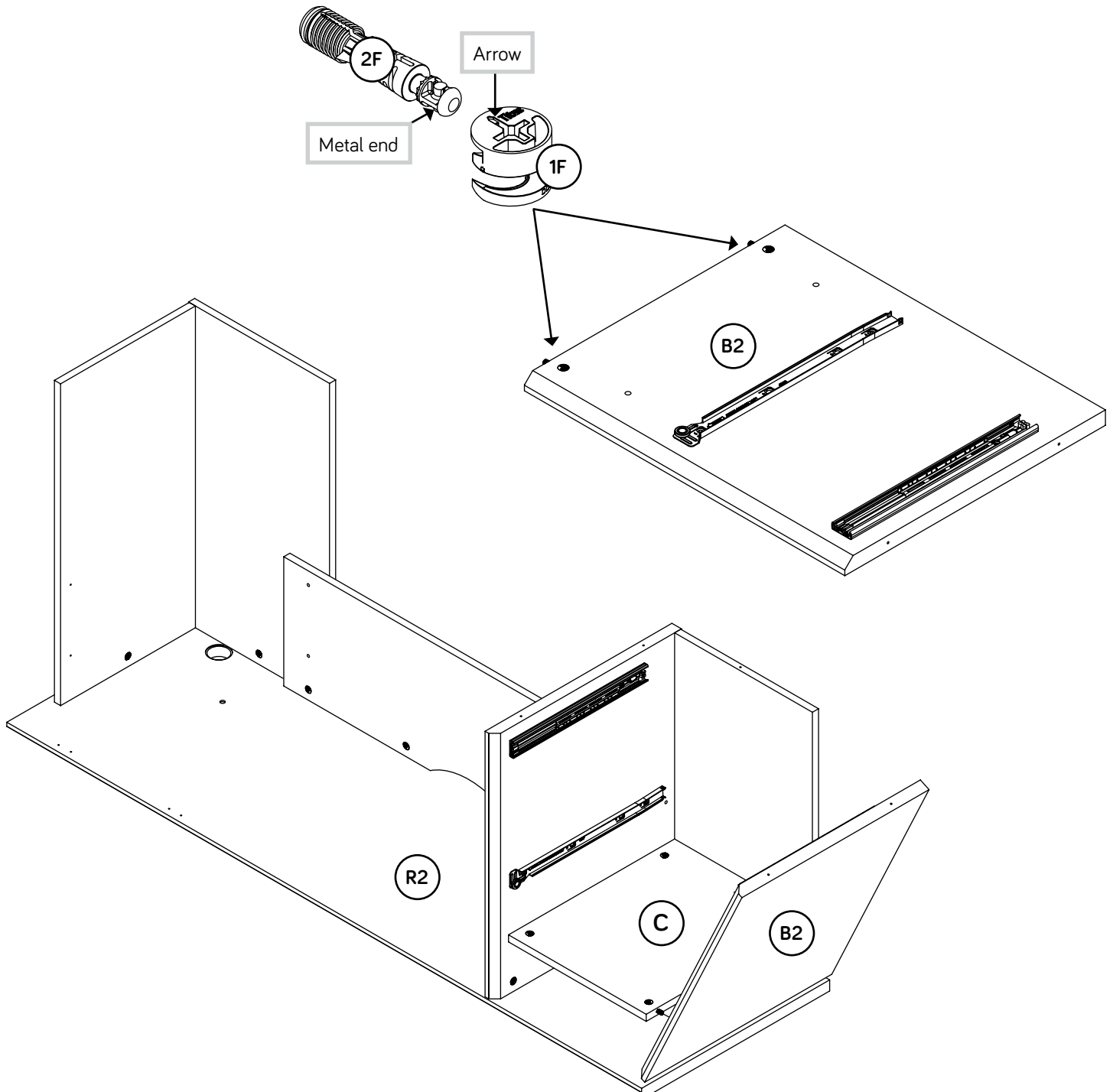

# Step 13

- Turn sixteen BLACK 15/16" SHOULDER SCREWS (144S) into each BOTTOM (E) until the shoulders of the SCREWS rest on the surface of the BOTTOMS.

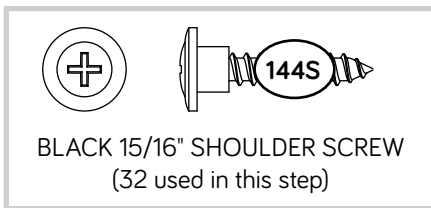
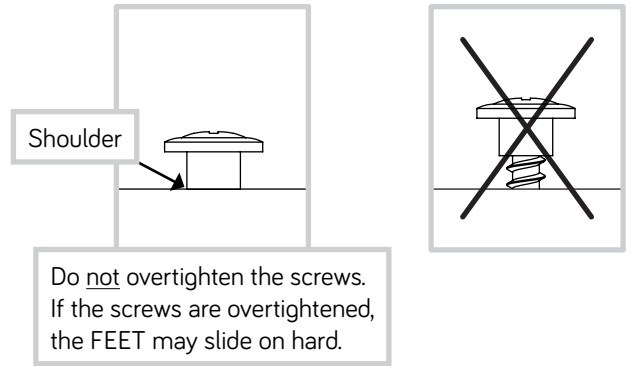

x2

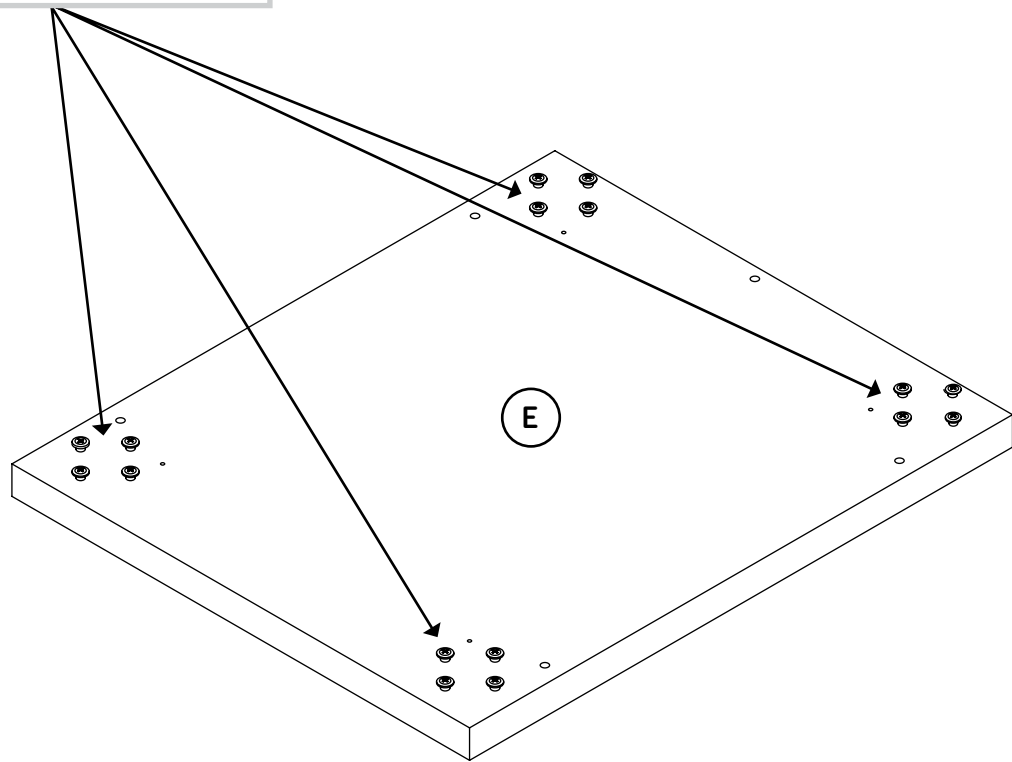

# Step 14

- ✚ Center the large slots in the FOOT (S) over the heads of the SCREWS in the BOTTOM (E). See diagram 1.
- ✚ With your hands, push the base of the FOOT (S) in the direction of the arrow until the SCREWS are seated in the small slots. See diagram 2.
- ✚ If it is difficult to slide the FOOT onto the screws, then remove the FOOT and slightly loosen the SCREWS. Place the FOOT back onto the SCREWS and repeat diagram 2.
- ✚ Tighten the SHOULDER SCREWS.
- ✚ Repeat this step for the remaining FEET (S).

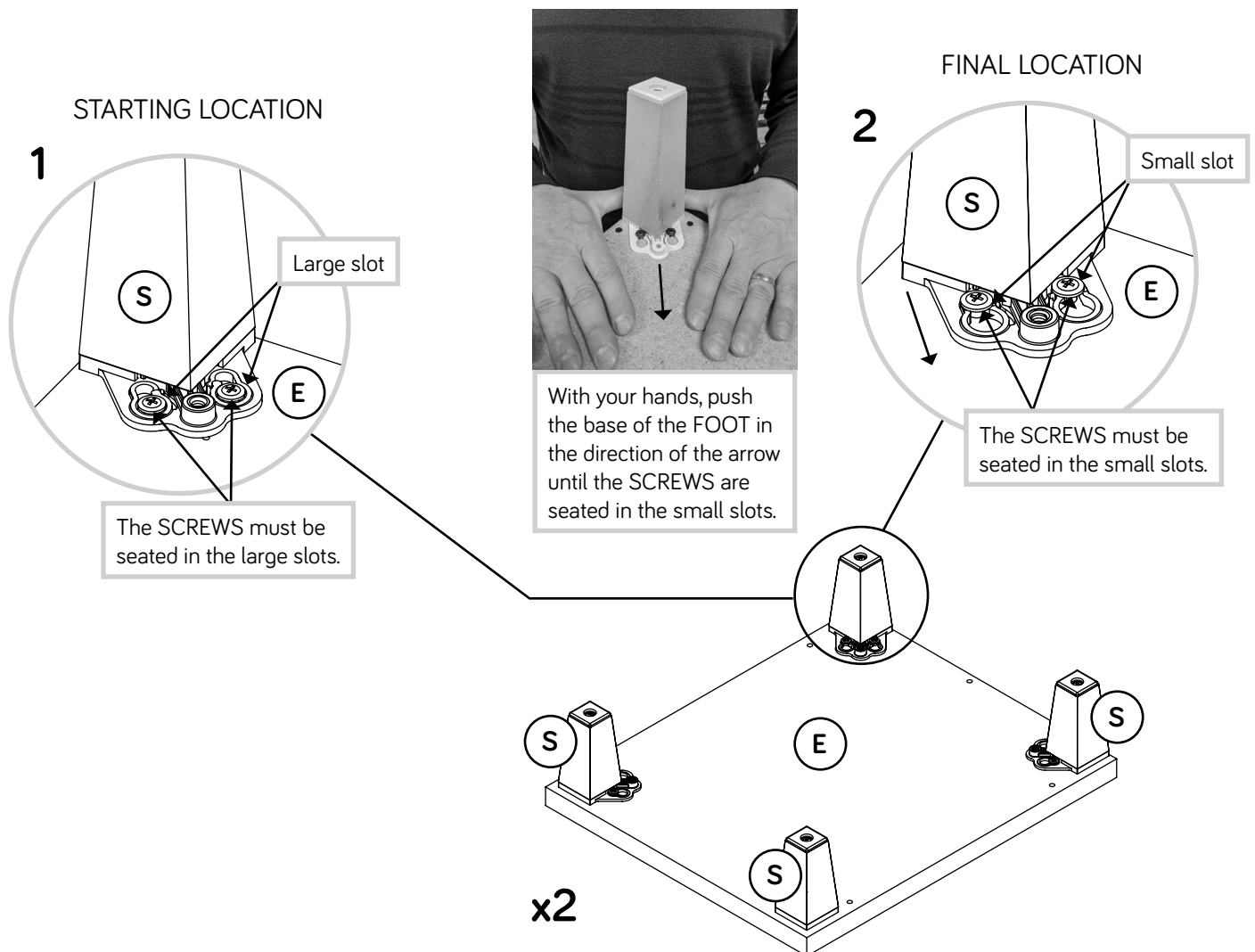
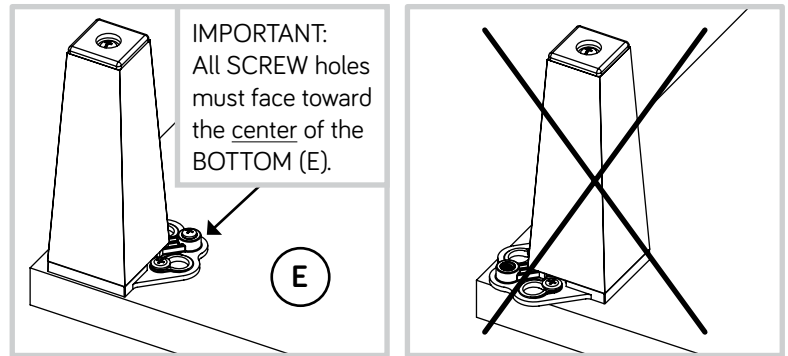

# Step 15

- ✚ Finish fastening the FEET (S) to the BOTTOMS (E).  
Use four BLACK 3/4" PAN HEAD SCREWS (85S)  
through the center hole in the FEET.

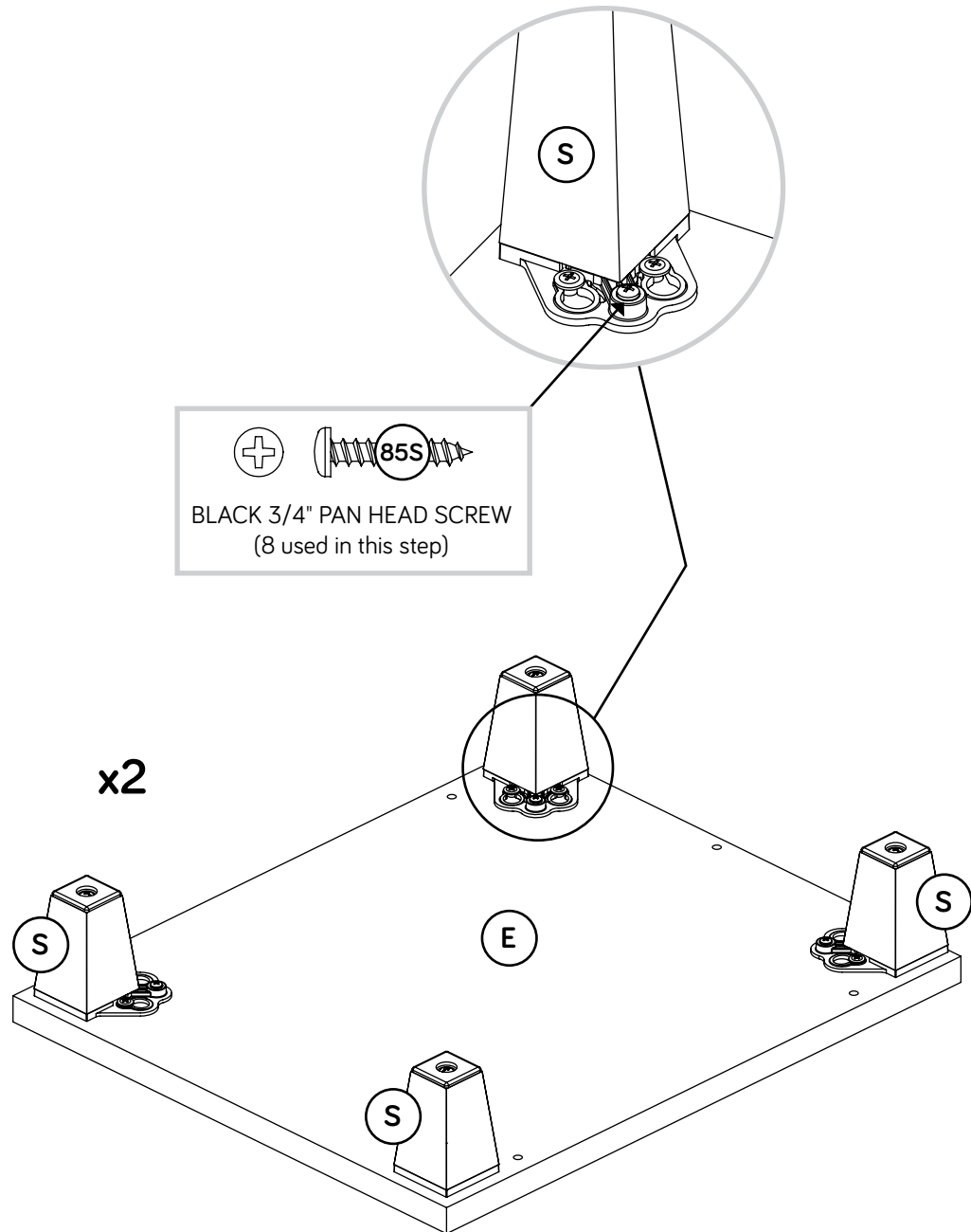

# Step 16

Fasten one BOTTOM (E) to the LEFT END (B2), BACK (L2), and LEFT UPRIGHT (Q2). Use five BLACK 2-3/8" FLAT HEAD SCREWS (146S).

**NOTE:** You should start each SCREW a few turns before completely tightening any of them.

Fasten two PLATES (41G) to the LARGE TOP (R2). Use four BLACK 9/16" LARGE HEAD SCREWS (1S).

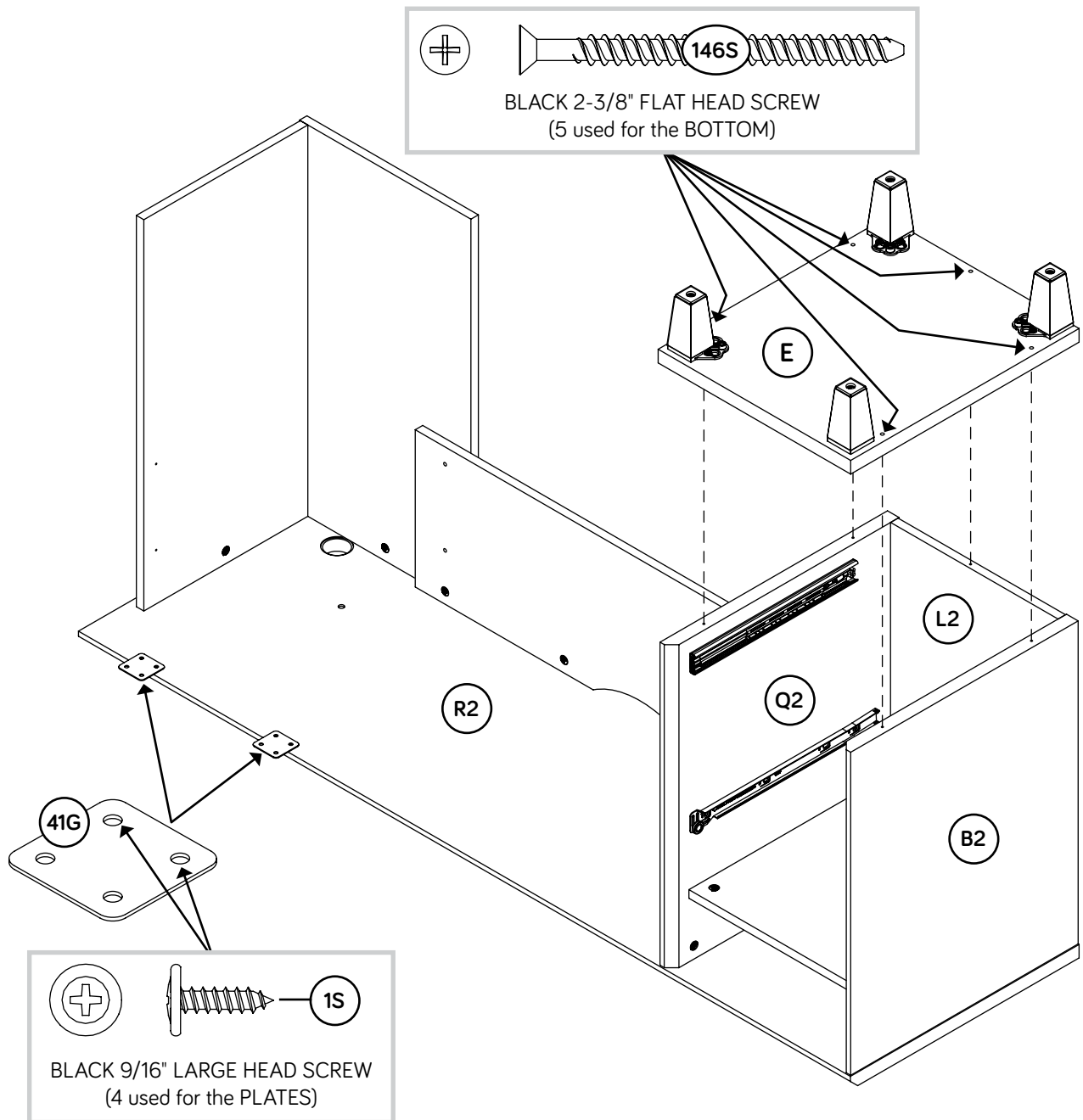

# Step 17

- ✚ Push two HIDDEN CAMS (1F) into the SMALL MODESTY PANEL (F2). Then, insert the metal end of a CAM DOWEL (2F) into each HIDDEN CAM.
- ✚ Fasten the SMALL MODESTY PANEL (F2) to the SMALL TOP (O2). Tighten two HIDDEN CAMS.

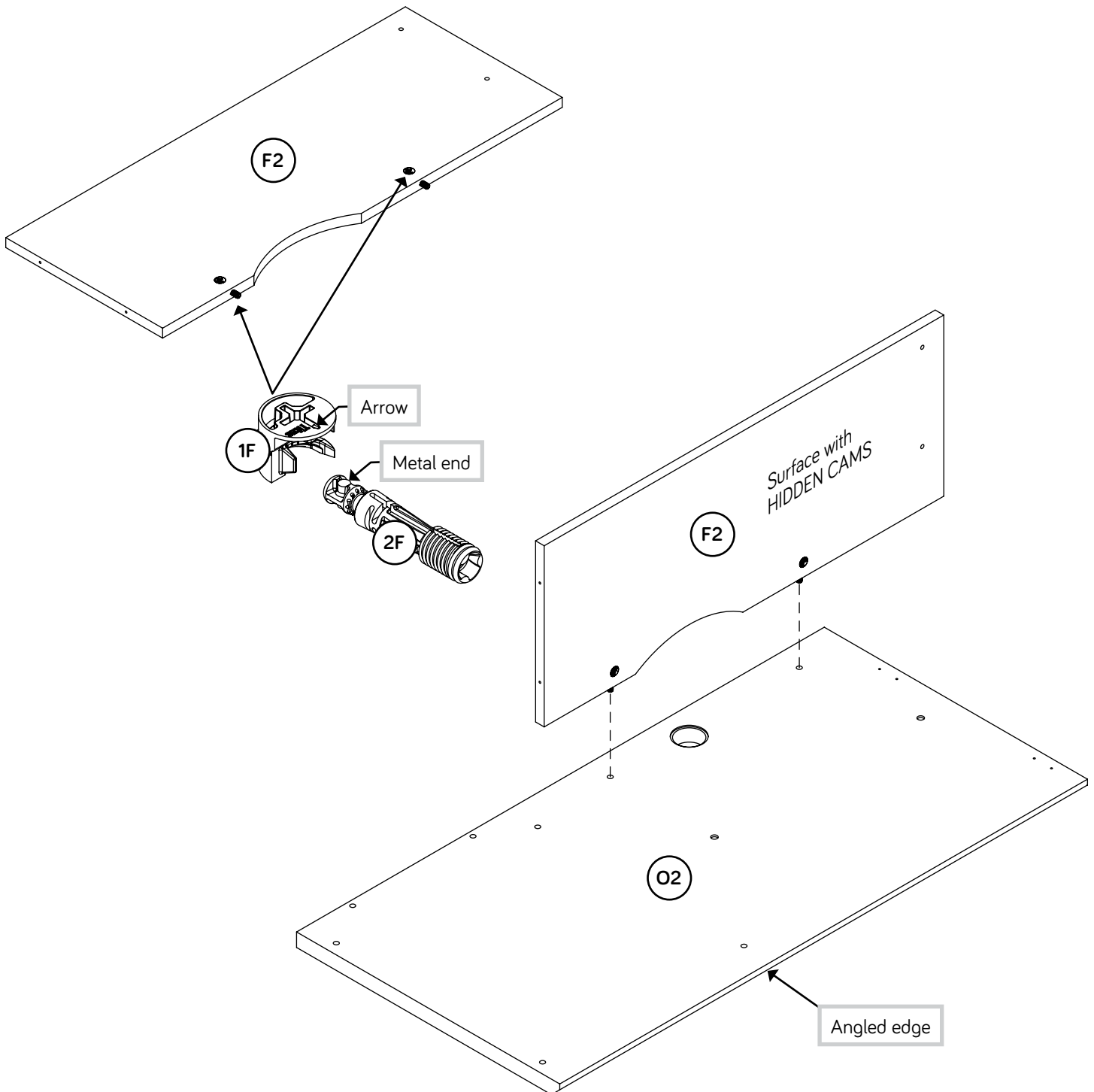

# Step 18

- ✚ Push two HIDDEN CAMS (1F) into the RIGHT UPRIGHT (P2). Then, insert the metal end of a CAM DOWEL (2F) into each HIDDEN CAM.
- ✚ Fasten the RIGHT UPRIGHT (P2) to the SMALL TOP (O2). Tighten two HIDDEN CAMS.
- ✚ Fasten the RIGHT UPRIGHT (P2) to the SMALL MODESTY PANEL (F2). Use two BLACK 2-3/8" FLAT HEAD SCREWS (146S).
- ✚ NOTE: You should start each SCREW a few turns before completely tightening any of them.

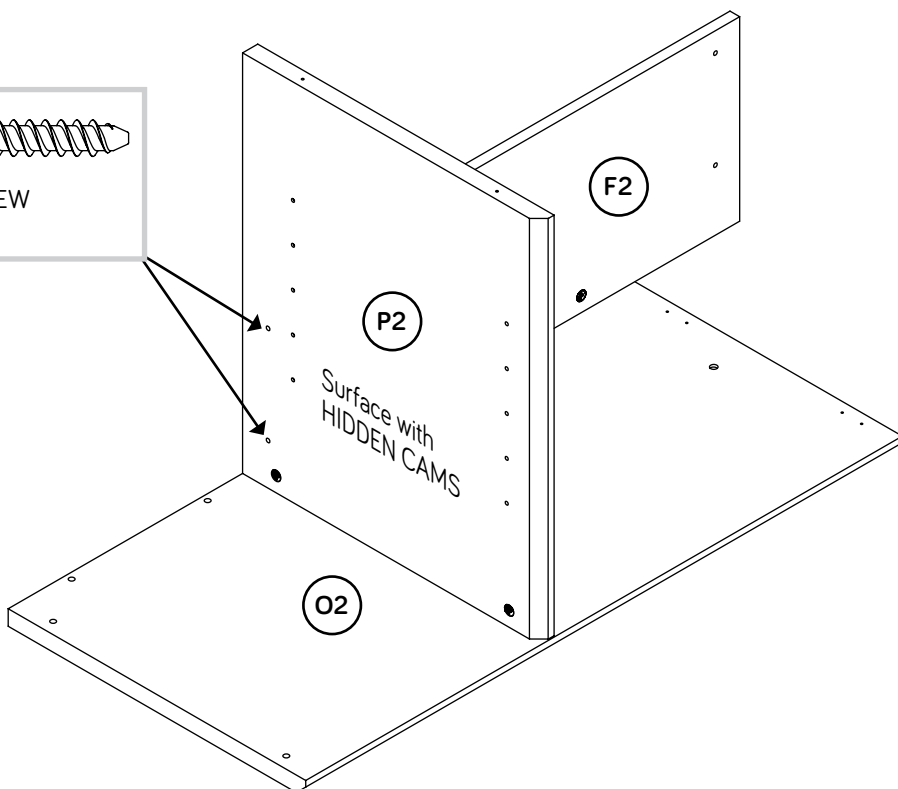
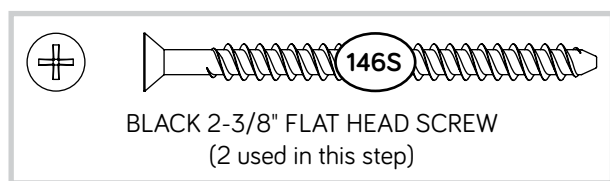
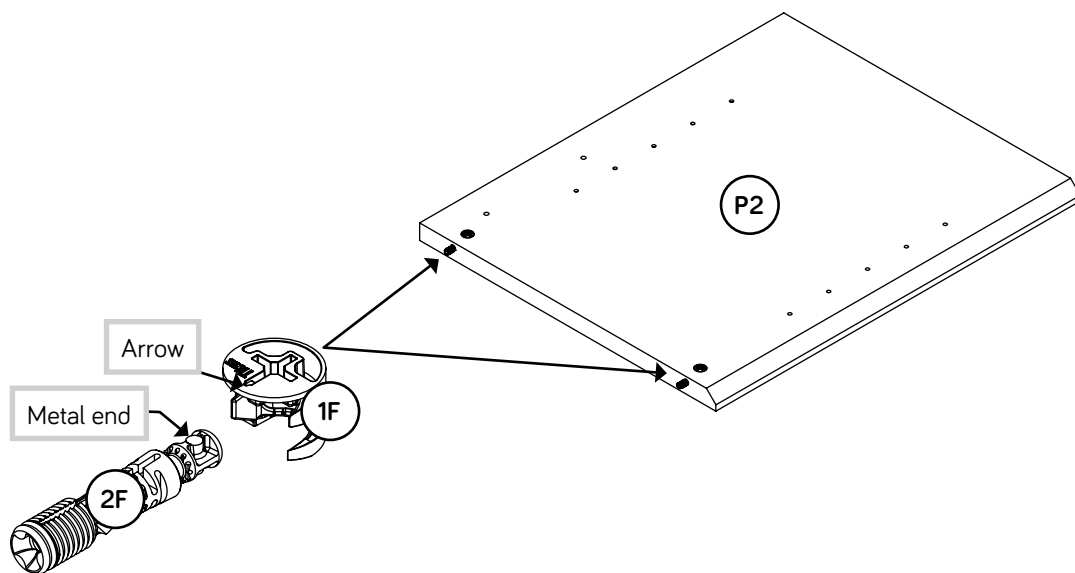

# Step 19

- ✚ Push two HIDDEN CAMS (1F) into the remaining BACK (L2). Then, insert the metal end of a CAM DOWEL (2F) into each HIDDEN CAM.
- ✚ Fasten the BACK (L2) to the SMALL TOP (O2). Tighten two HIDDEN CAMS.

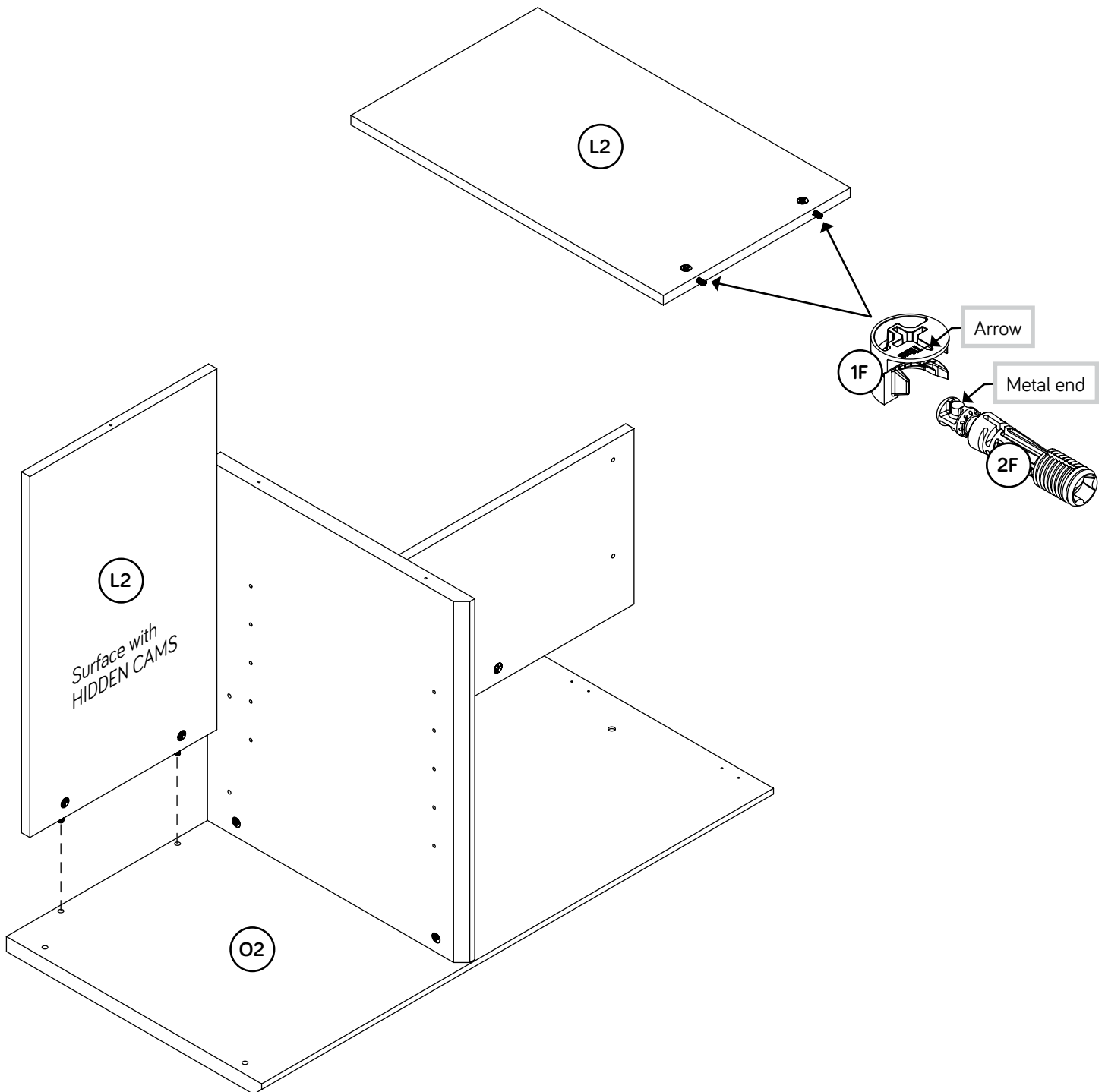

# Step 20

- ✚ Push two HIDDEN CAMS (1F) into the RIGHT END (A2).  
Then, insert the metal end of a CAM DOWEL (2F) into each HIDDEN CAM.
- ✚ Fasten the RIGHT END (A2) to the SMALL TOP (O2).  
Tighten two HIDDEN CAMS.

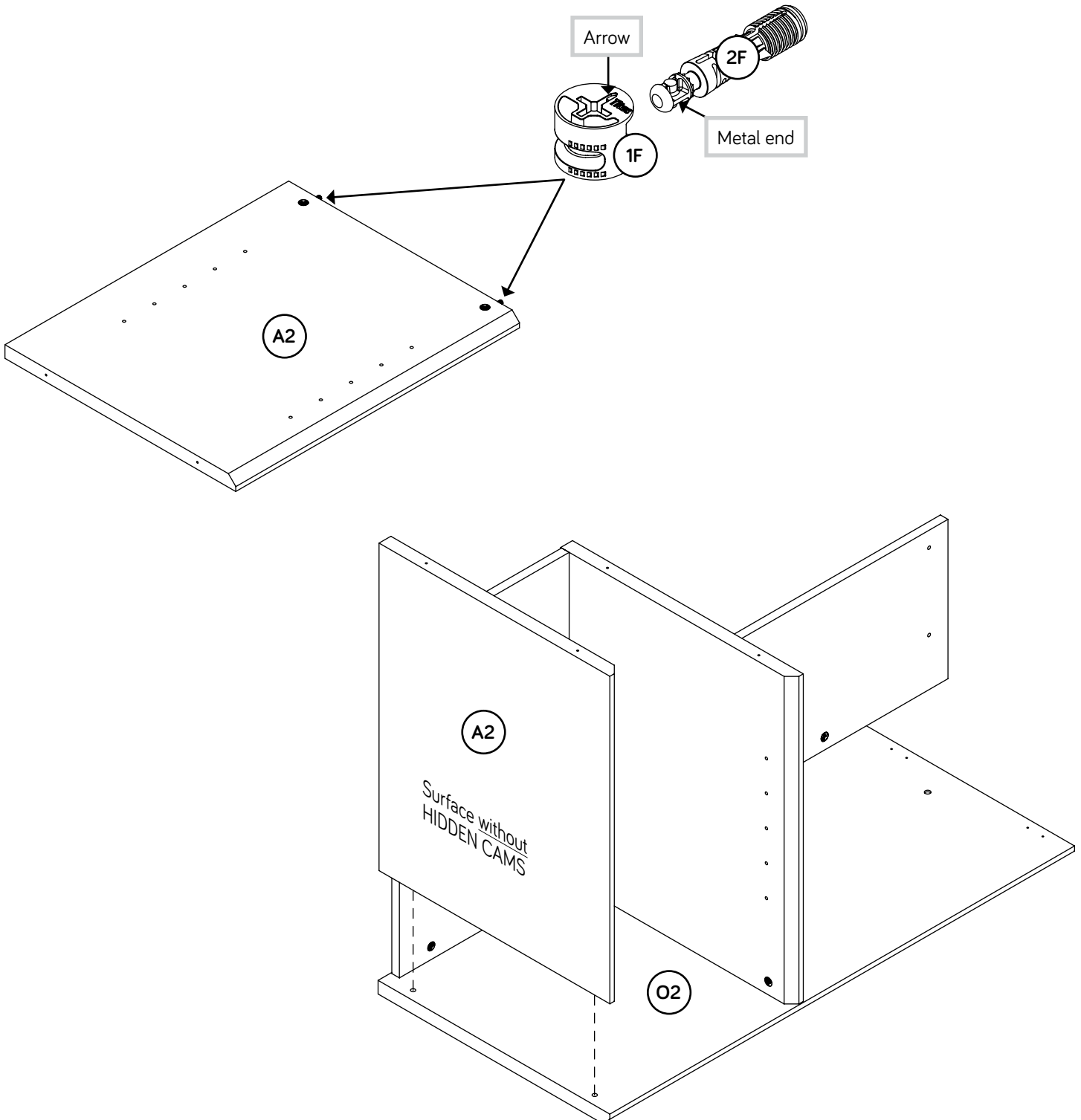

# Step 21

✚ Fasten the remaining BOTTOM (E) to the RIGHT END (A2), BACK (L2), and RIGHT UPRIGHT (P2).  
Use five BLACK 2-3/8" FLAT HEAD SCREWS (146S).

✚ NOTE: You should start each SCREW a few turns before completely tightening any of them.

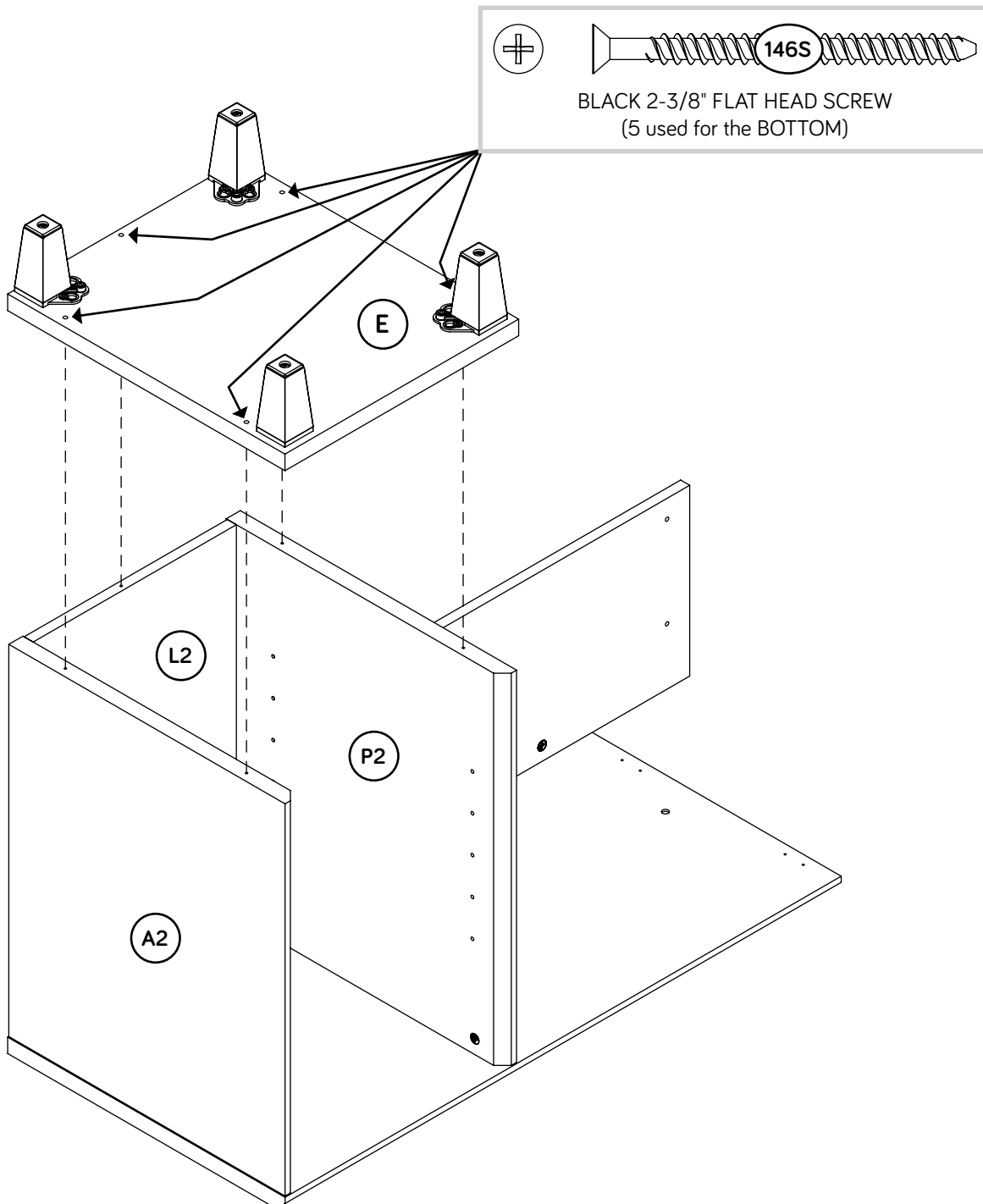

# Step 22

- ✚ With someone's help, carefully stand both assemblies upright near your unit's final location.
- ✚ First, fasten the SMALL TOP (O2) to the PLATES on the LARGE TOP (R2). Use four BLACK 9/16" LARGE HEAD SCREWS (1S).
- ✚ Then, fasten the SMALL MODESTY PANEL (F2) to the RIGHT CORNER UPRIGHT (J2). Use two SILVER 1-1/8" FLAT HEAD SCREWS (10S).
- ✚ **NOTE:** You should start each SCREW a few turns before completely tightening any of them.
- ✚ Using your hammer, gently tap a CAM COVER (13P) onto each HIDDEN CAM closest to the front edges of the ENDS (A2 and B2) and UPRIGHTS (P2 and Q2).

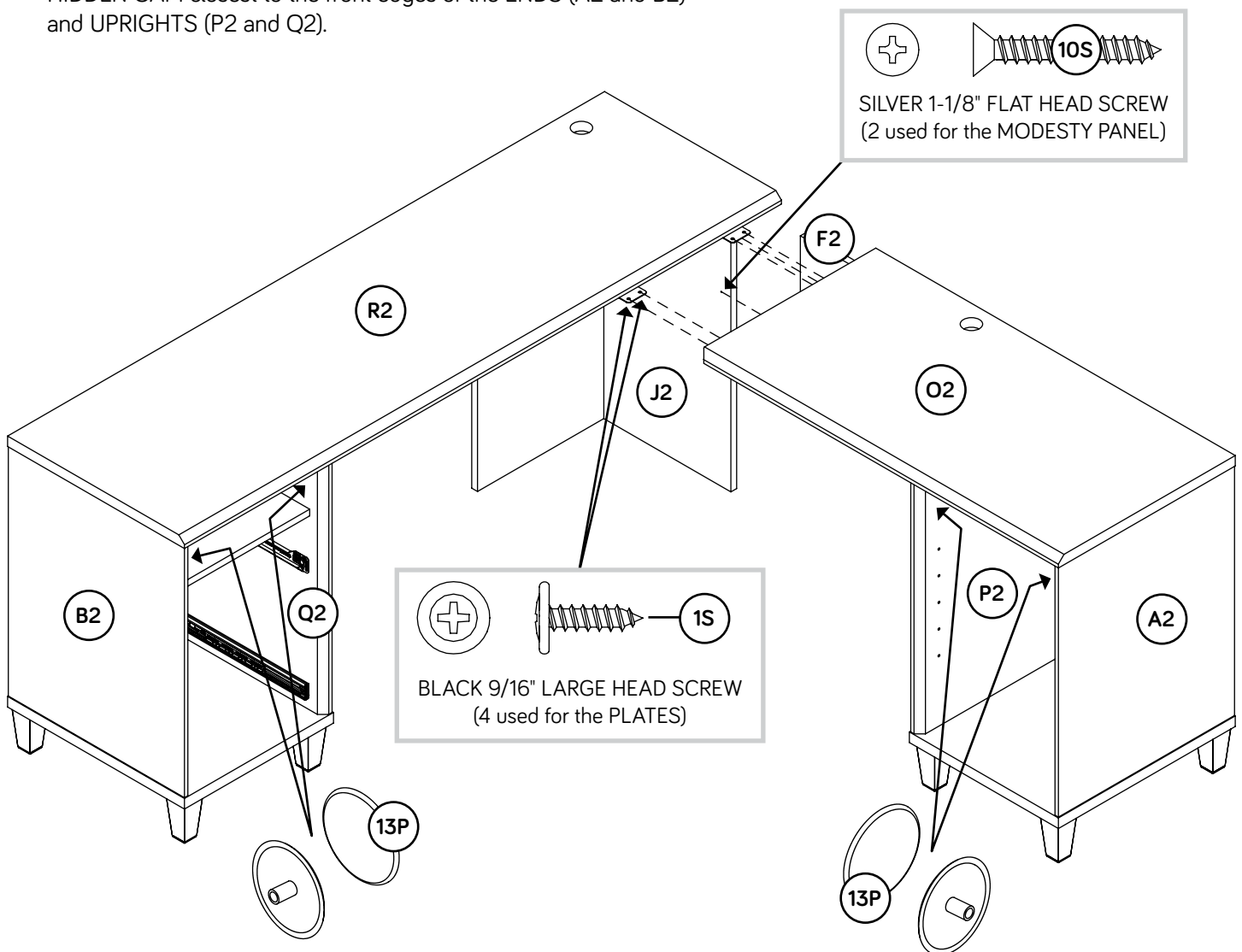

# Step 23

- ✚ Push three SAUDER TWIST-LOCK® FASTENERS (10F) into the large holes in the BRACE (N).
- ✚ Fasten the BRACE (N) to the TOPS (O2 and R2). Tighten three TWIST-LOCK® FASTENERS.

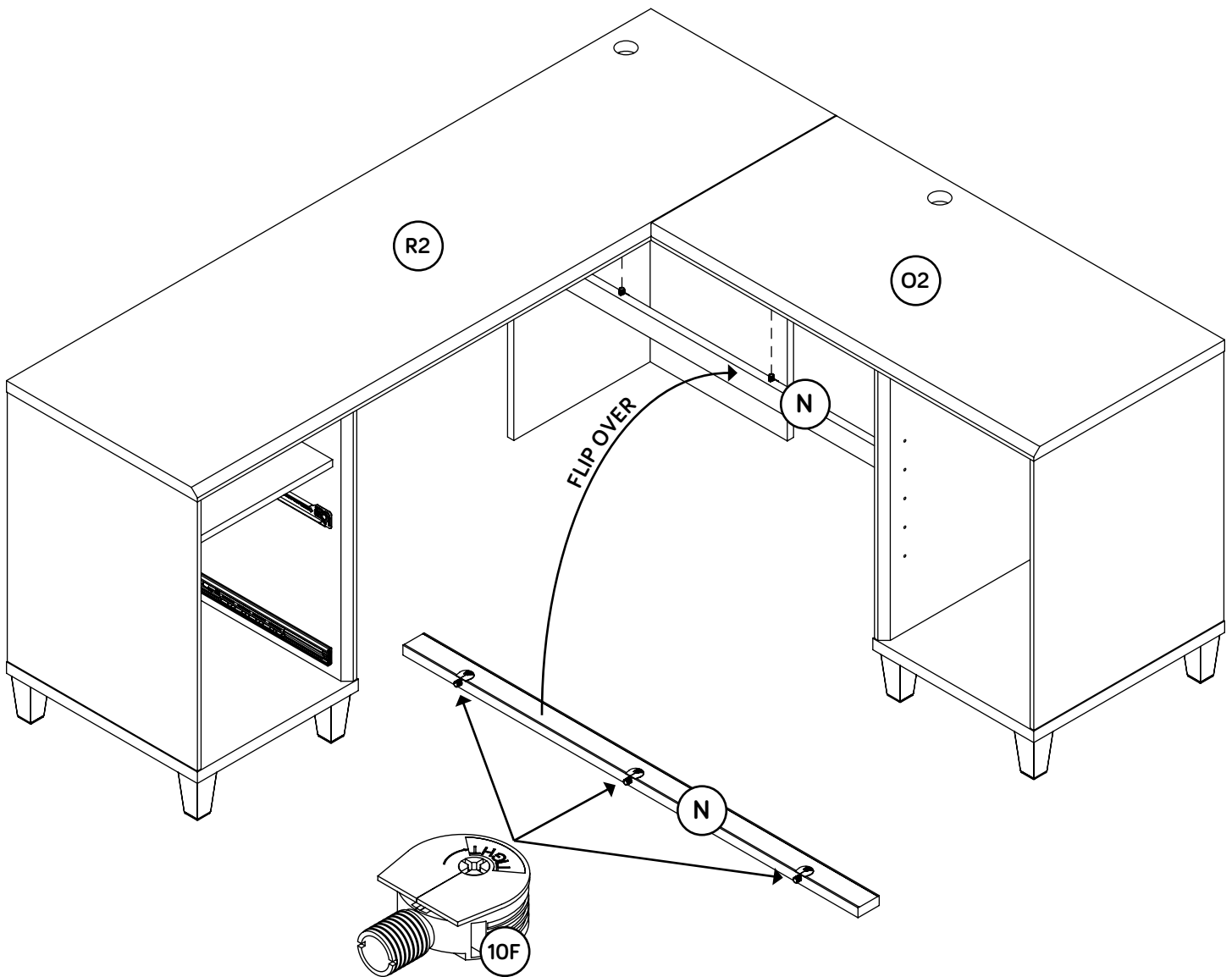

# Step 24

1

The tabs should insert freely into the slots. Gently tilt the DRAWER SIDES side to side until the tabs slip into the slots.

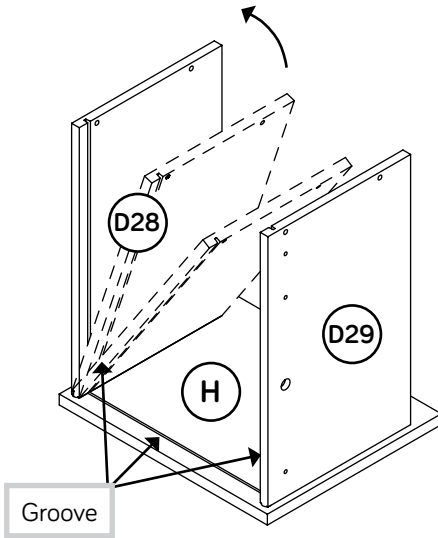

✚ Insert the LARGE DRAWER SIDES (D28 and D29) at an angle into the slot at each end of the LARGE DRAWER FRONT (H).

2

With the palm of your hand, tap the DRAWER BOTTOM down into the groove.

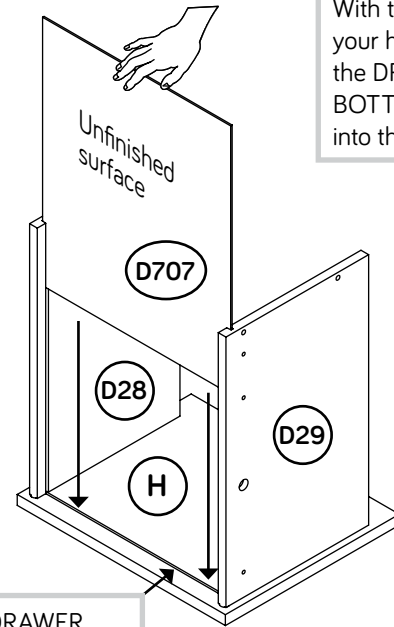

Be sure the DRAWER BOTTOM inserts into the DRAWER FRONT groove.

✚ Slide the DRAWER BOTTOM (D707) into the grooves in the LARGE DRAWER SIDES (D28 and D29) and LARGE DRAWER FRONT (H).

3

Be sure the DRAWER BOTTOM inserts into the DRAWER BACK groove.

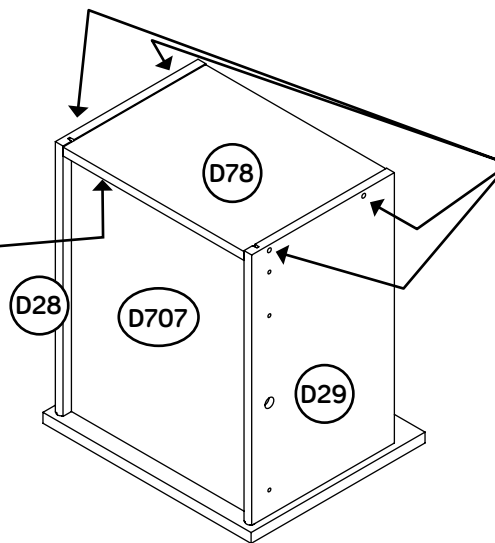

Start each screw a few turns before completely tightening any of them.

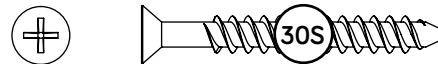

BLACK 1-9/16" FLAT HEAD SCREW  
(4 used in this step)

✚ Fasten the LARGE DRAWER BACK (D78) to the LARGE DRAWER SIDES (D28 and D29). Use four BLACK 1-9/16" FLAT HEAD SCREWS (30S).

✚ NOTE: Be sure the DRAWER BOTTOM (D707) inserts into the groove of the LARGE DRAWER BACK (D78).

# Step 25

- ✚ Insert a SLIDE CAM (10A) into the LARGE DRAWER SIDES (D28 and D29).
- ✚ Fasten the EXTENSION SLIDES (35MC) to the LARGE DRAWER SIDES (D28 and D29).  
Use four GOLD 5/16" FLAT HEAD SCREWS (3S) through holes #1 and #3.
- ✚ **NOTE:** The screw head in the CAM must be visible through the slotted hole in the SLIDE.
- ✚ Fasten one KNOB (208K) to the LARGE DRAWER FRONT (H). Use one BLACK 7/8" MACHINE SCREW (37S).

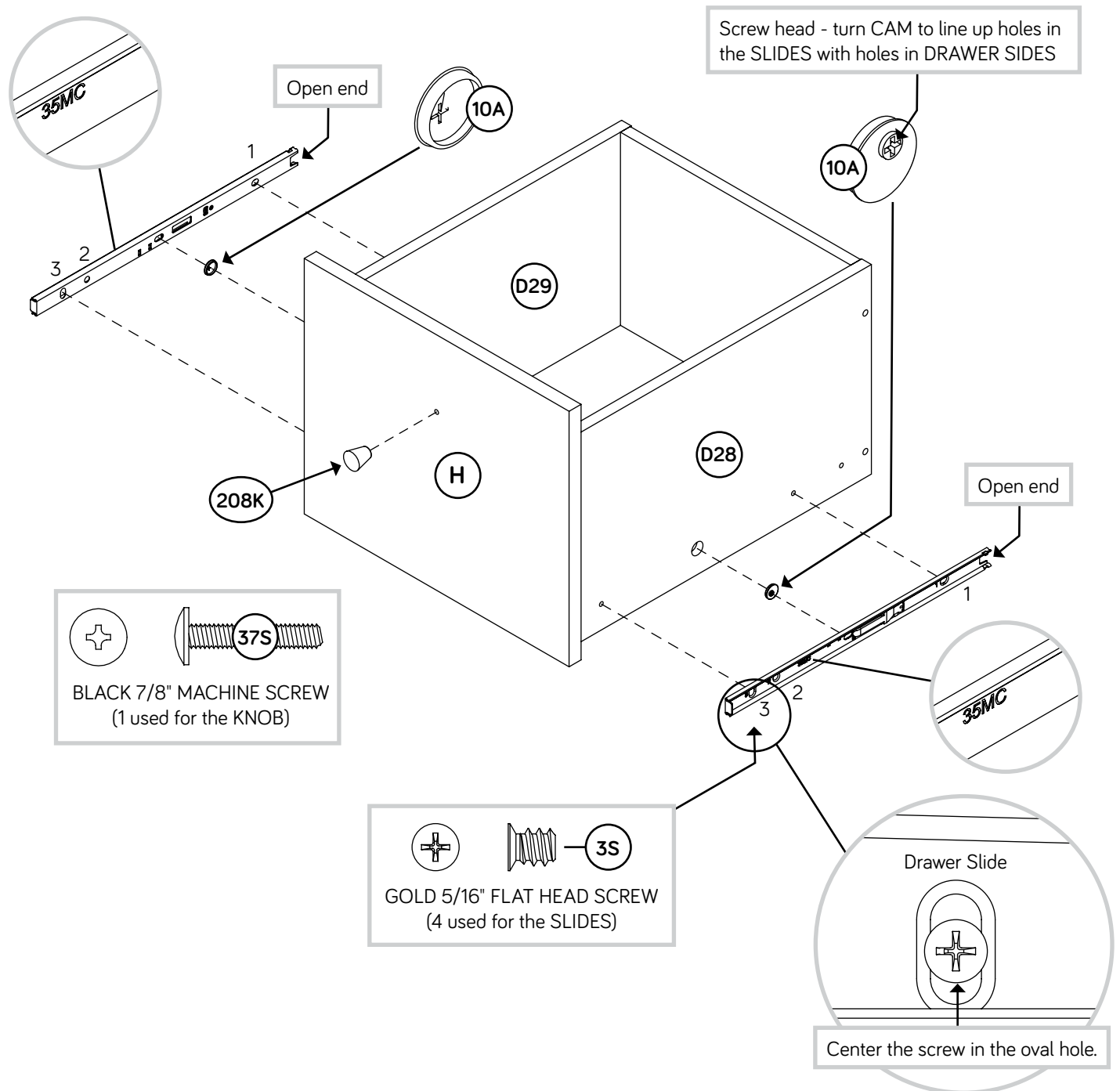

# Step 26

- ✚ Push a FILE GLIDE (15B) onto the LARGE RIGHT DRAWER SIDE (D28).
- ✚ Slide the FILE RODS (8B) into the FILE GLIDE (15B) on the LARGE RIGHT DRAWER SIDE.
- ✚ Slide another FILE GLIDE (15B) onto the other end of the FILE RODS (8B), then press this FILE GLIDE over the LARGE LEFT DRAWER SIDE (D29).

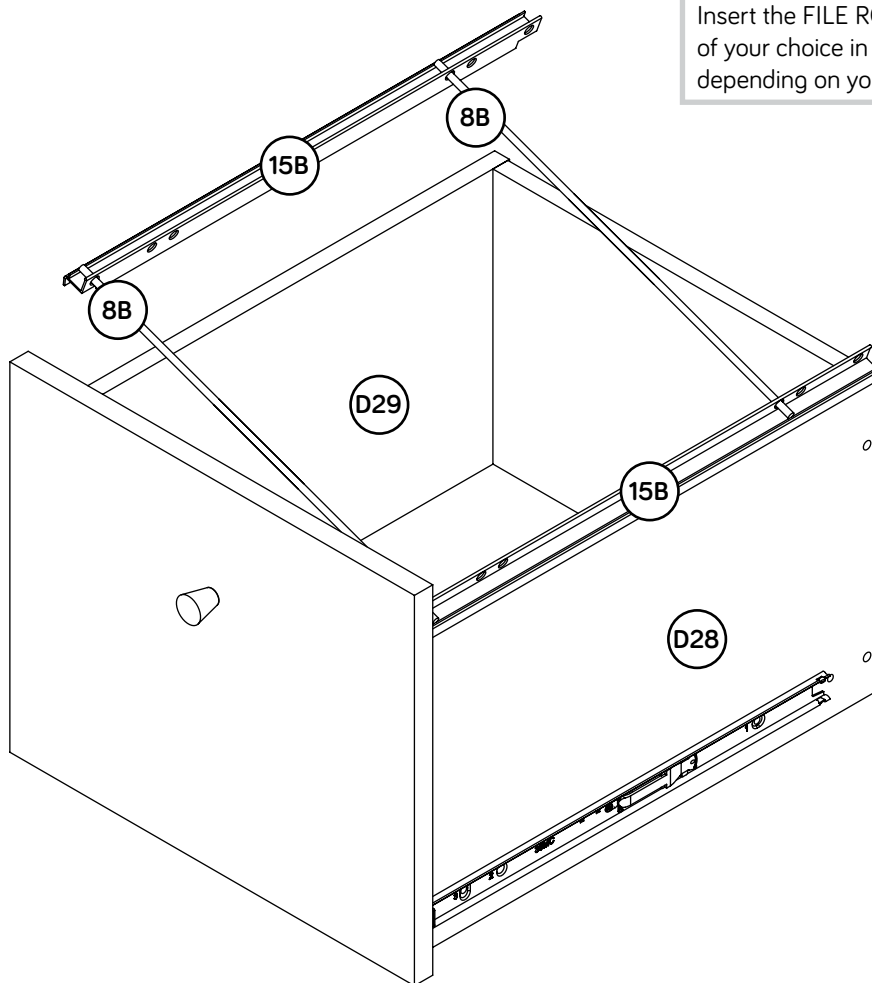

Insert the FILE RODS into the holes of your choice in the FILE GLIDES, depending on your file sizes.

# Step 27

1

The tabs should insert freely into the slots. Gently tilt the DRAWER SIDES side to side until the tabs slip into the slots.

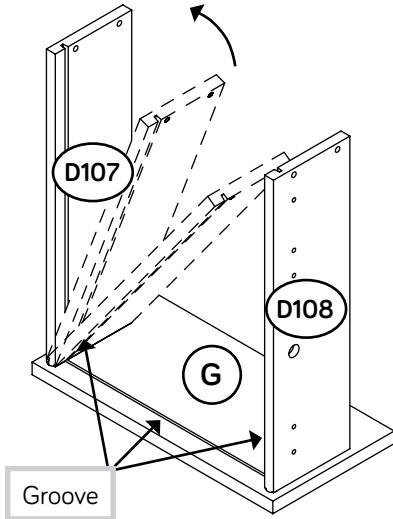

- ✦ Insert the SMALL DRAWER SIDES (D107 and D108) at an angle into the slot at each end of the SMALL DRAWER FRONT (G).

2

With the palm of your hand, tap the DRAWER BOTTOM down into the groove.

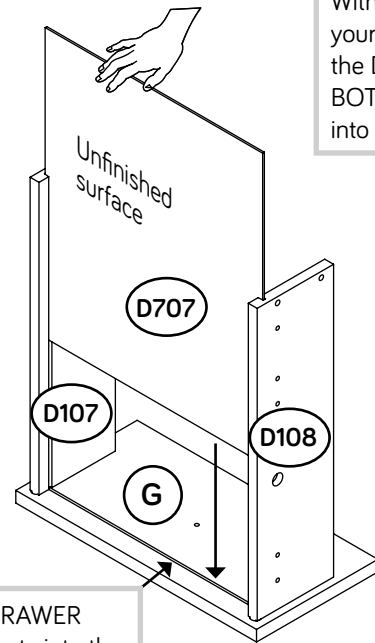

Be sure the DRAWER BOTTOM inserts into the DRAWER FRONT groove.

- ✦ Slide the DRAWER BOTTOM (D707) into the grooves in the SMALL DRAWER SIDES (D107 and D108) and SMALL DRAWER FRONT (G).

3

Be sure the DRAWER BOTTOM inserts into the DRAWER BACK groove.

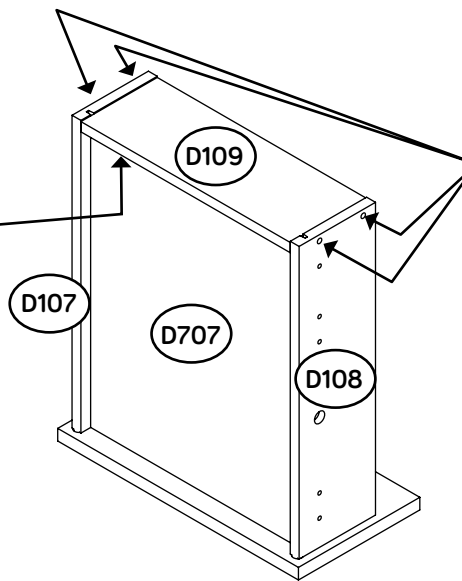

Start each screw a few turns before completely tightening any of them.

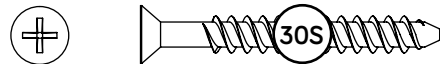

BLACK 1-9/16" FLAT HEAD SCREW  
(4 used in this step)

- ✦ Fasten the SMALL DRAWER BACK (D109) to the SMALL DRAWER SIDES (D107 and D108). Use four BLACK 1-9/16" FLAT HEAD SCREWS (30S).

- ✦ **NOTE:** Be sure the DRAWER BOTTOM (D707) inserts into the groove of the SMALL DRAWER BACK (D109).

# Step 28

- ✚ Insert a SLIDE CAM (10A) into the SMALL DRAWER SIDES (D107 and D108).
- ✚ Fasten the DRAWER RIGHT (40CC) to the SMALL RIGHT DRAWER SIDE (D107) and the DRAWER LEFT (40CD) to the SMALL LEFT DRAWER SIDE (D108). Use four GOLD 5/16" FLAT HEAD SCREWS (3S) through holes #1 and #4.
- ✚ **NOTE:** The screw head in the CAM must be visible through the slotted hole in the SLIDE.
- ✚ Fasten one KNOB (208K) to the SMALL DRAWER FRONT (G). Use one BLACK 7/8" MACHINE SCREW (37S).

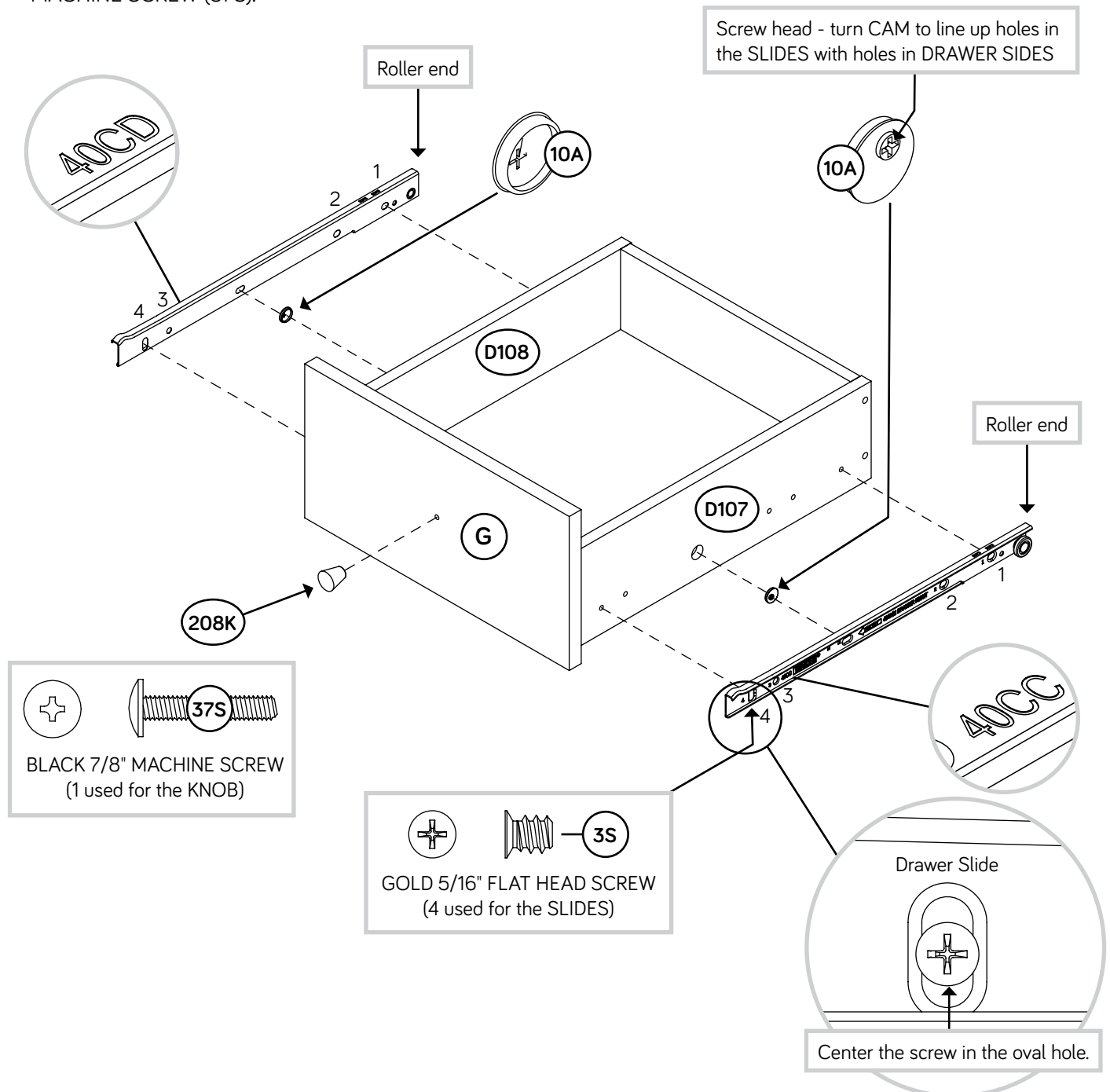

# Step 29

- ✚ Push the RUBBER SLEEVES (2R) over one end of the SHELF RESTS (1R). Insert the SHELF RESTS into the hole locations of your choice in the RIGHT END (A2) and RIGHT UPRIGHT (P2). Set the ADJUSTABLE SHELF (M) onto the SHELF RESTS.
- ✚ Insert the GROMMETS (7P) and GROMMET CAPS (8P) into the large holes in the TOPS (O2 and R2).
- ✚ Center a SCREW COVER (18P) over the head of each SCREW in the CORNER UPRIGHTS (J2 and K) and gently tap in with your hammer.

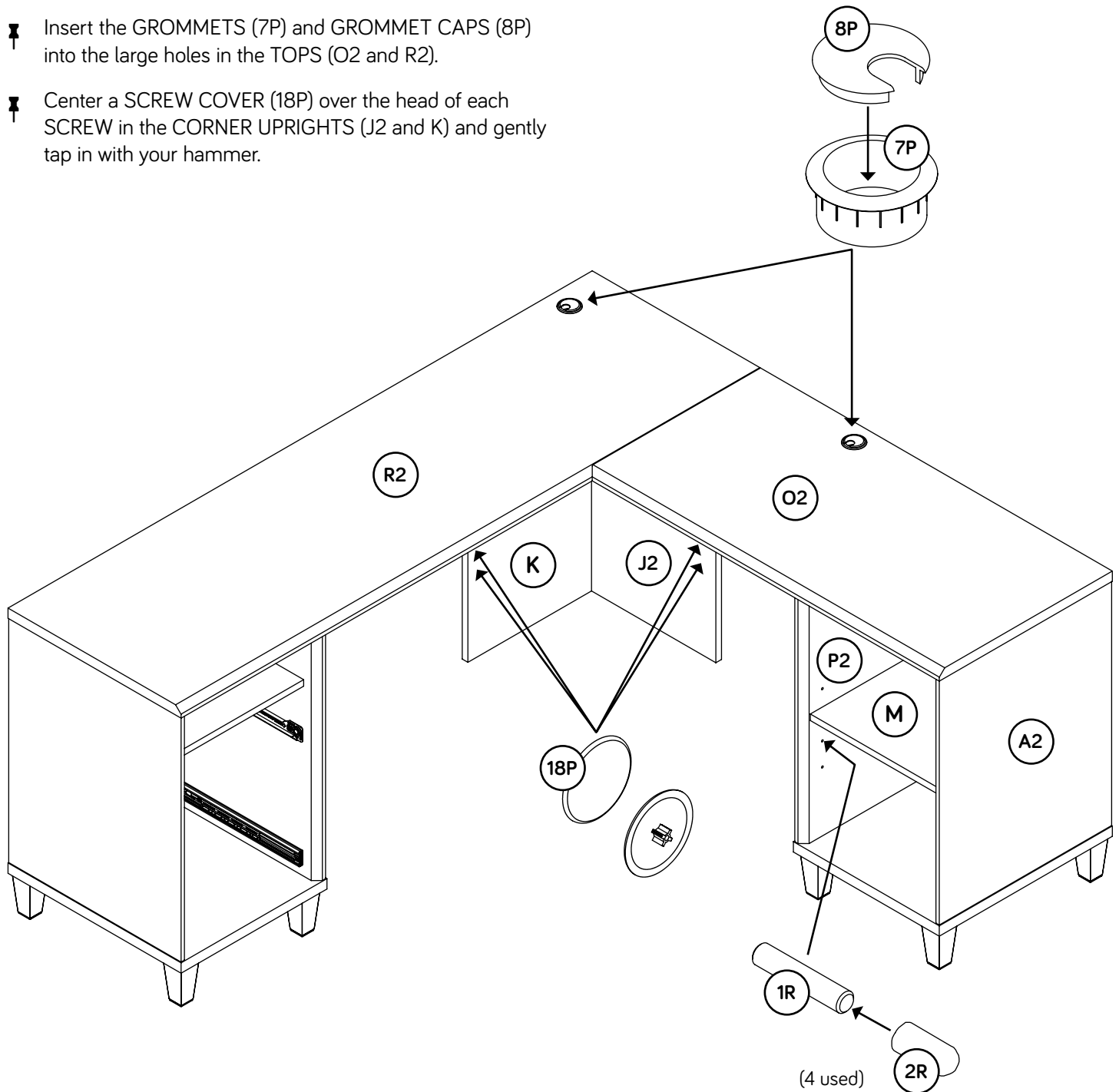

# Step 30

- ✦ To insert the SMALL DRAWER (G) into your unit, tip the front of the drawer down and drop the rollers on the drawer behind the rollers on the unit. Lift the front of the drawer up and slide it into the unit.
- ✦ To insert the LARGE DRAWER (H) into your unit, line up the EXTENSION SLIDES on the drawer with the EXTENSION RAILS on the unit and push the drawer into the unit until the drawer is fully inserted. The drawer will push in hard until it is all the way in, then it will slide in and out easier.

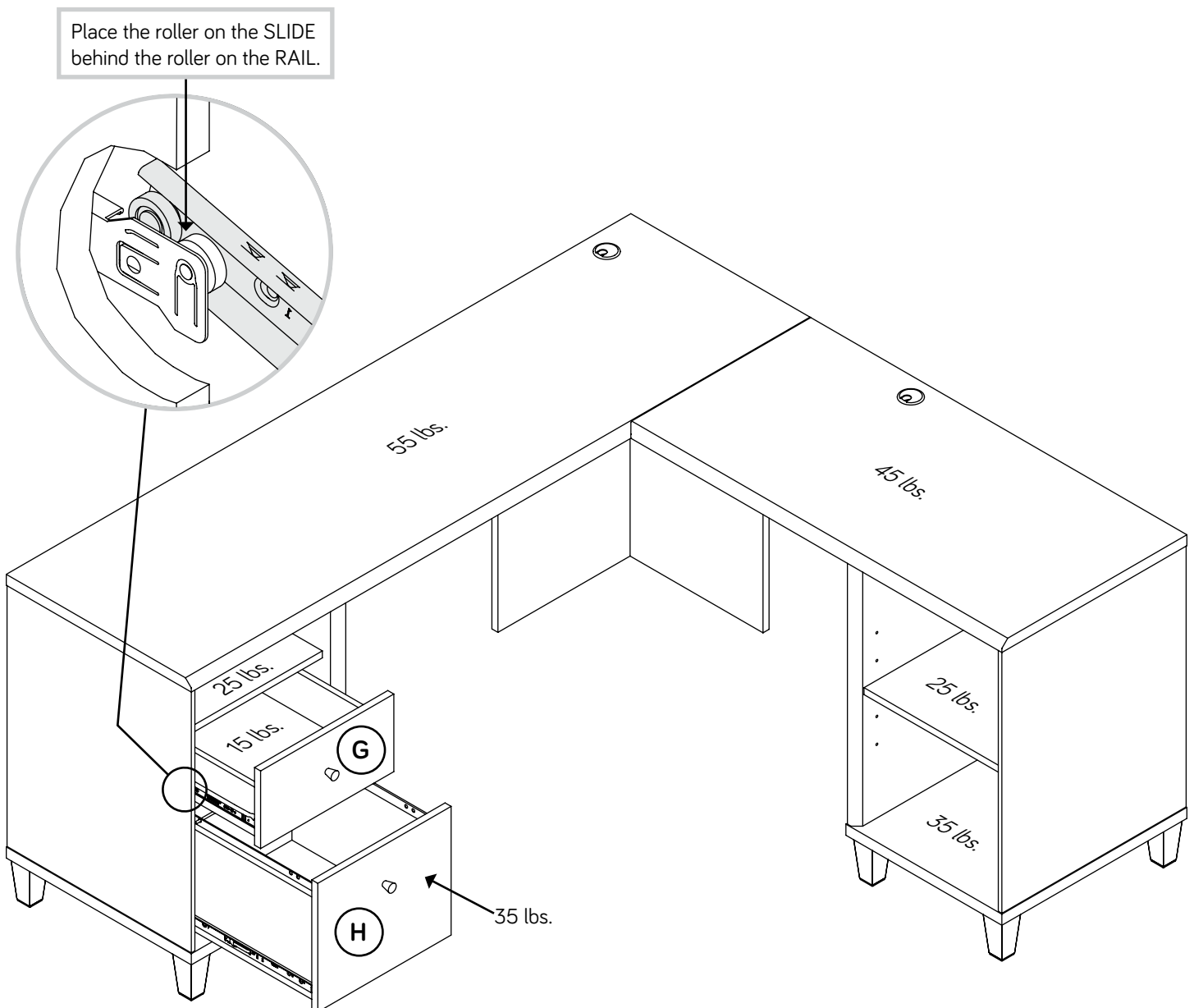

# Step 31

- ✚ To make adjustments to the SMALL drawer, loosen SCREW #4 in the SLIDES a 1/4 turn, then turn the cam clockwise or counter-clockwise. Notice how the drawer raises or lowers as you turn the cam. By adjusting the drawer this way, it will help the DRAWER FRONT line up better when closed. Tighten the SCREWS when finished with adjustments.
- ✚ NOTE: Repeat this step for the LARGE drawer using SCREW #3.
- ✚ NOTE: Please read the back pages of the instruction booklet for important safety information.
- ✚ This completes assembly. Clean with a damp cloth. Wipe dry.

Loosen screw #4 a 1/4 turn, turn the cam a 1/4 turn maximum in both the clockwise and counter-clockwise directions to make adjustments, and then tighten screw #4.

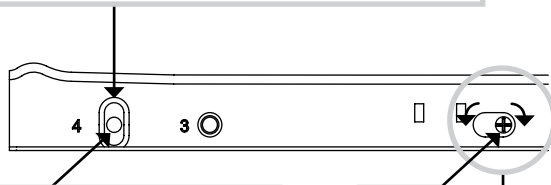

The higher the screw in the oblong hole, the higher your drawer front will be. The lower the screw, the lower the drawer front.

