



TM

Z-1000
OWNER'S MANUAL



Welcome to clean air with TruSens. Thank you for allowing us to join you on your journey towards wellness.

Enjoy cleaner air in your home with PureDirect™ Technology & DuPont™ Filtration that ensure the whole room benefits from cleaner air.

CONTENTS

SAFETY INFORMATION	4
FEATURE HIGHLIGHTS	5
CONTROL PANEL	6
PRODUCT OVERVIEW	7
GETTING STARTED	8
SPECIFICATIONS	10
CARE & MAINTENANCE	11
Replacing HEPA Filter	11
Replacing Carbon Filter	12
Replacing UV Bulb	13
FAQ & TROUBLESHOOTING	14
GUARANTEE & SUPPORT	15

SAFETY INFORMATION

PLEASE READ AND SAVE THESE INSTRUCTIONS

Unplug or disconnect the appliance from the power supply before replacing filters or UV-C emitter, or when appliance is not in use.



WARNING:

To reduce the risk of fire or electric shock, do not use this fan with any solid-state speed control device.

Do not operate any purifier with a damaged cord or plug, or if the wall socket is loose. If the supply cord is damaged, it must be replaced by the manufacturer, its service agent or similarly qualified persons in order to avoid a hazard.

Do not run cord under carpeting, throw rugs, runners, or similar coverings. Do not run cord under furniture or appliances. Arrange cord away from traffic area and where it will not be tripped over.



WARNING: Skin or eye damage may result from directly viewing the light produced by the UV-C emitter in this apparatus. Unintended use of the appliance or damage to the housing may result in the escape of dangerous UV-C radiation. UV-C radiation may, even in little doses, cause harm to the eyes and skin. Always disconnect power before relamping or servicing. Replace UV-C emitter with item 2415105, Manufactured by ACCO Brands.

- Remove all packaging, including the filter bag, before use.
- Appliances that are obviously damaged must not be operated.
- This appliance must only be connected to a wall socket outlet matching the supply plug type and rating stated on the rating plate.
- Locate air purifier near the outlet wall socket and do not use extension cords.
- This appliance can be used by children aged from 8 years and above and persons with reduced physical, sensory or mental capabilities or lack of experience and knowledge if they have been given supervision or instruction concerning use of the appliance in a safe way and understand the hazards involved.
- Children shall not play with, clean, or try to maintain the appliance.
- Replace the UV-C emitter with the model specified within this manual.
- Do not attempt to service or repair this product yourself.
- Only use the purifier with the power cable provided.
- Only clean this machine with a damp cloth, do not use solvents or bleach.
- Ensure appliance is always placed on firm level surface before operation.
- Do not block or obstruct the air intake or outlet vents.
- Do not insert fingers or other items into the air intake or outlet vents.

FEATURE HIGHLIGHTS



PureDirect™ Technology

Independent lab testing confirms that two airflow streams are better than one, moving air effectively and more comfortably throughout the room.



360° Purification

DuPont™ HEPA filter captures pollutants and VOC gases/odours from all directions. UV light kills germs and bacteria that can get trapped in the filter.



Thoughtful Execution

Exceptional functionality wrapped in a contemporary design that fits any environment.

CONTROL PANEL

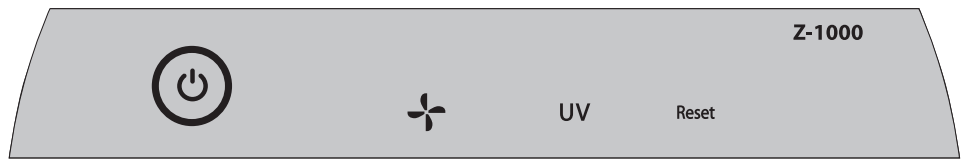

Power Button



Fan Speed Settings

Select fan speed: 1, 2, or Turbo.

UV

UV Mode

UV bulb within the purifier's filter chamber is on when the ☀️ symbol is white. The ☀️ symbol will glow red when it is time to replace the UV bulb.

(See page 13 for replacement instructions)

Reset

Filter and UV Indicator Reset

HEPA, Carbon and UV indicators glow red when it is time for each to be replaced. When 1 indicator is on, simply hold Reset for 3 seconds to reset that indicator. When 2+ indicators are on, tap the Reset button to select the correct indicator (selected indicator will blink) before holding 3 seconds to reset that indicator.

(See pages 11-13 for replacement instructions. Follow above Reset button instructions after replacing filter.)

PRODUCT OVERVIEW

Air Purifier

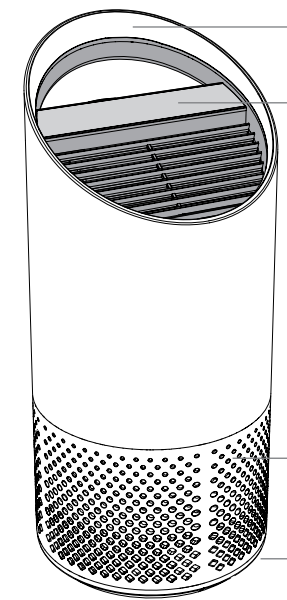

Easy-carry handle

Simple touch control panel

360° air intake

Filter cover & knob (underneath)

Filter & Ultraviolet Sterilisation

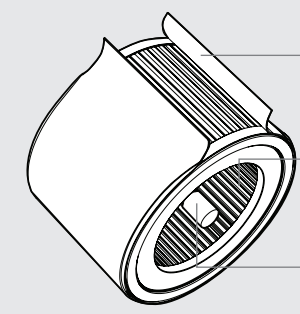

Carbon Prefilter

HEPA Filter

UV Sterilisation

GETTING STARTED



1. Remove plastic bag from filter

Unscrew the bottom cover and remove the plastic bag from the filter.

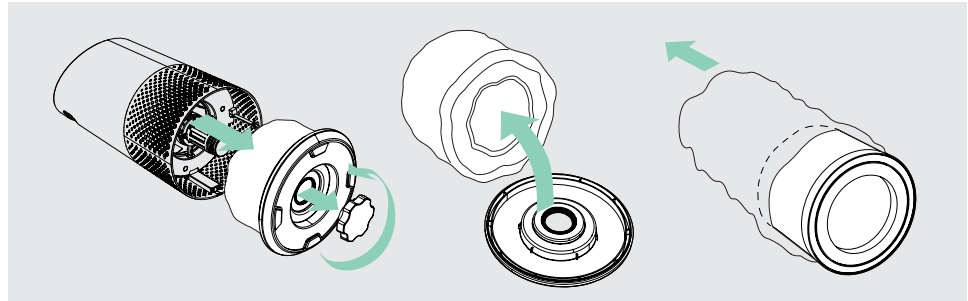

2. Re-attach filter

Secure filter on the bottom cover and replace inside the purifier.

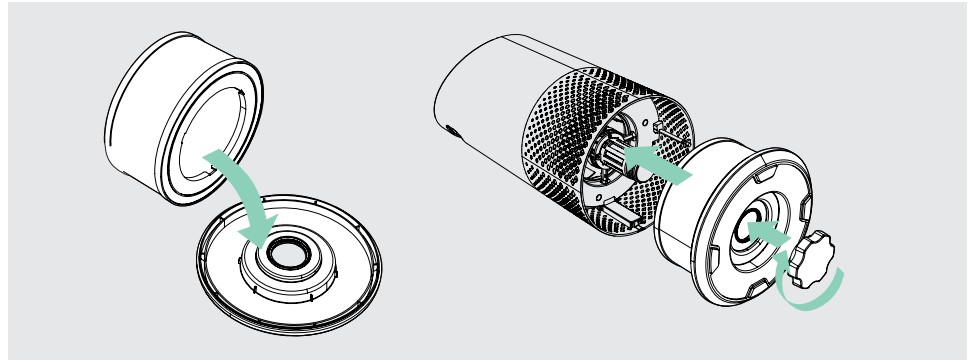

3. Set up

Plug-in your air purifier unit and power on.

Place the purifier on a flat surface, free from obstructions:

- where air can flow freely into the purifier from all sides
- avoiding furnishings like bedding and curtains, as well as sources of heat or moisture

4. Start living with cleaner air!

Select your preferred fan speed and proprietary PureDirect™ technology will deliver purified air throughout the room!

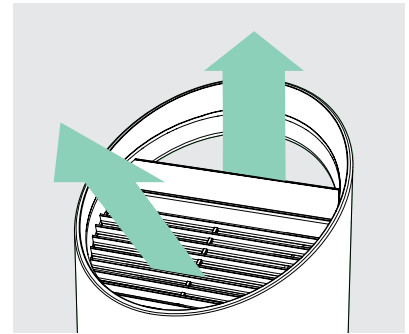
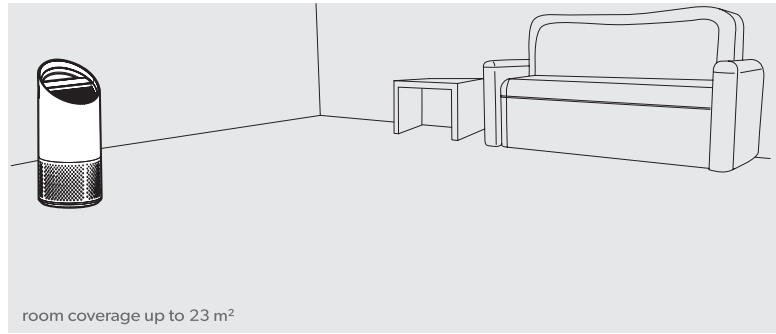

SPECIFICATIONS

Air Inlet	360°
Air changed 2 times per hr	23 m ²
Air Delivery Type	PureDirect™
Fan Speed Settings	1, 2, Turbo
Purification Levels	Carbon Prefilter, HEPA, UV
Filter Change Indicators	Carbon, HEPA, UV
Noise	39 - 65 dB
Dimensions	195 x 195 x 451 mm
Weight	3.5 kg
Motor Type	AC motor
Power Requirements	220-240v 50/60Hz 0.5A
Power Consumption	40 W
Warranty	2 years

Replacement Filters & UV Bulb

2-in-1 HEPA drum filter	2415104
Carbon Prefilter (3-pack)	2415103
UV Bulb	2415105

CARE & MAINTENANCE

Accessing the filter chamber

1. Always power off the purifier by pressing the Power Button and unplugging the power cord.
2. Gently place the unit on its side on the floor so that the filter chamber cover and knob are exposed.
3. Turn the knob counter-clockwise and remove the filter cover and 360° HEPA filter drum (Fig. A).

REPLACING HEPA FILTER

1. The HEPA indicator will glow red when it is time to change the entire HEPA drum filter.
2. Gently pull the HEPA drum filter away from its place secured to the filter cover (Fig. B).
3. Secure the replacement HEPA filter onto the filter cover (Fig. C).
4. Gently replace the filter cover with filter drum into the filter chamber and onto the threading, and turn the knob clockwise until the knob and filter chamber cover are securely tightened (Fig. D).
5. Plug-in and power on your purifier, and hold the Reset button until the red HEPA indicator turns off.

Note: HEPA drum filter (on page 10) will include 2 layers: Carbon Prefilter and HEPA

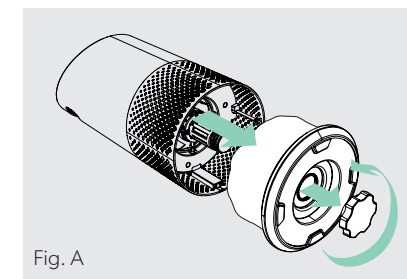

Fig. A

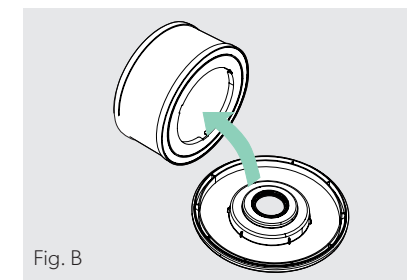

Fig. B

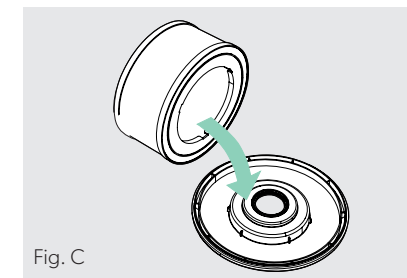

Fig. C

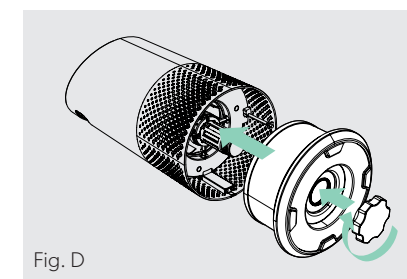

Fig. D

REPLACING CARBON PREFILTER

1. The Carbon indicator will glow red when it is time to replace the Carbon layer.
2. Gently peel away the used Carbon layer from the fastener strips (Fig. E).
3. Wrap a new Carbon layer around the filter drum and attach to the same fastener strips (Fig. F).
4. Once the purifier is powered-on, hold the Reset button until the red Carbon indicator turns off.

Note: Carbon Prefilter 3-pack (on page 10) will cover 3 Carbon changes between replacing the entire HEPA drum filter assembly (on page 11).

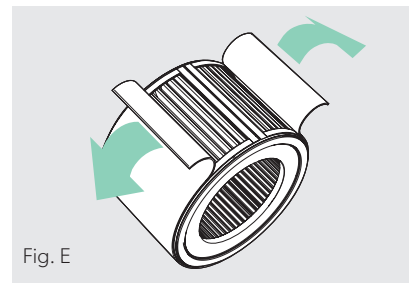

Fig. E

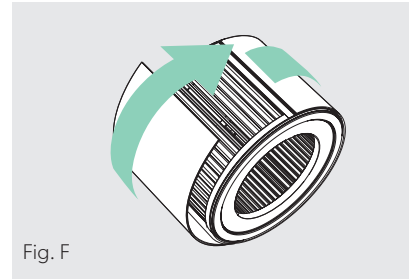



Fig. F

REPLACING UV BULB

1. The  indicator will glow red when it is time to replace the UV bulb.
2. Remove HEPA filter drum (Fig. A), and use a screwdriver to remove the screw securing the UV housing (Fig. G).
3. Gently remove the UV housing (Fig. H) and disconnect the UV bulb from the socket (Fig. I).
4. Release carriage from the UV bulb (Fig. J).
5. Secure carriage to new UV bulb (on page 10) (Fig. K) and connect UV bulb into purifier (Fig L).
6. Replace the UV housing and use a screwdriver to tighten the fastening screw.
7. Once the purifier is powered-on, hold the Reset button until the  indicator turns white.

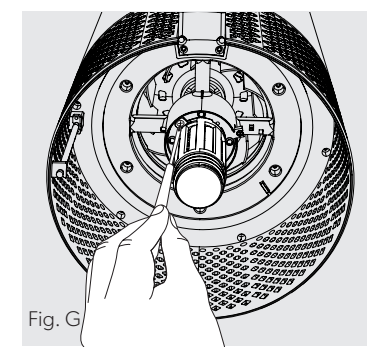

Fig. G

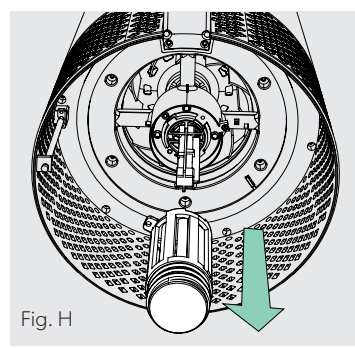

Fig. H

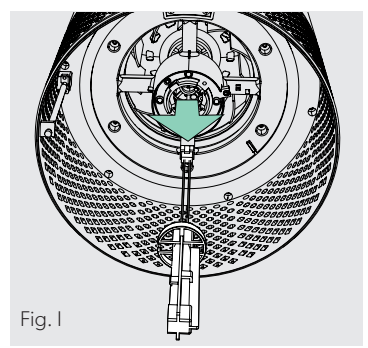

Fig. I

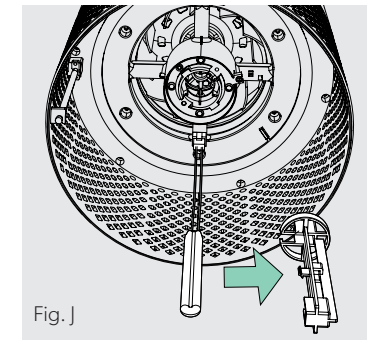

Fig. J

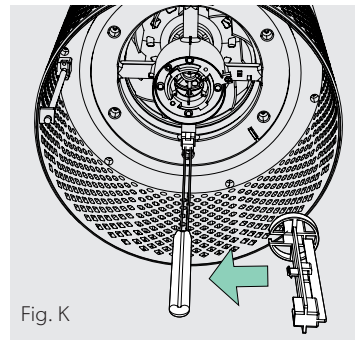

Fig. K

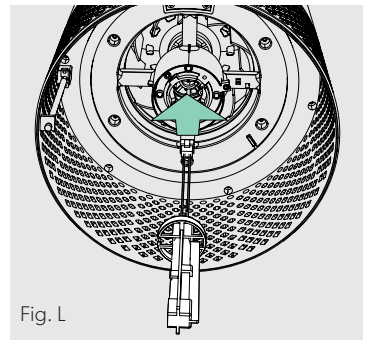

Fig. L

FAQ & TROUBLESHOOTING

<p>How often do I need to change the filters?</p>	<p>That's easy! The purifier's replacement indicators will notify you when it is time to replace the Carbon or HEPA filters, or the UV bulb. Plan on replacing the Carbon every 3-4 months, HEPA every 12-15 months, and UV bulb every 1-3 years.</p>
<p>Purifier won't turn on.</p>	<p>Check that the power cord is connected securely to both the wall outlet and the purifier. Check if there is a power outage in the outlet by trying a nearby light or device, or by trying a working device in the same outlet. Check that the HEPA filter is fitted properly into filter chamber.</p> <p>Please contact us if you're still having a problem! (page 15)</p>

GUARANTEE

Operation of this machine is guaranteed for two years from date of purchase, subject to normal use. Within the guarantee period, ACCO Brands Europe will at its own discretion either repair or replace the defective machine free of charge. Defects due to misuse or use for inappropriate purposes are not covered under the guarantee. Proof of date of purchase will be required. Repairs or alterations made by persons not authorized by ACCO Brands Europe will invalidate the guarantee. It is our aim to ensure that our products perform to the specifications stated. This guarantee does not affect the legal rights which consumers have under applicable national legislation governing the sale of goods.

SUPPORT

Thank you for welcoming TruSens™ into your home. Our customers are at the heart of what we do, and we strive to design products that fit your lifestyle. If you have any questions or feedback, please reach out!

Visit our website at www.trusens.com

Email us at service.uk@acco.com

Call us at **0800 279 5102**

Ireland: **(01) 6038010**

M-Th **09:00 - 16:30**

F **09:00-16:00**

TruSens™

www.trusens.com



ACCO Brands Europe
Oxford House
Aylesbury HP21 8SZ
United Kingdom
www.accobrand.com

©2019 ACCO Brands. All rights reserved. TruSens™, U™ & Design and PureDirect™ are trademarks of ACCO Brands. DuPont™ & the Oval logo are trademarks or registered trademarks of E.I. du Pont de Nemours and Company used under license.

21973P003