

HOOVER

USER MANUAL

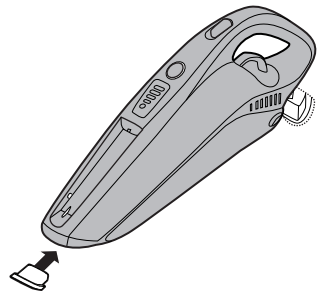

BORN INNOVATIVE

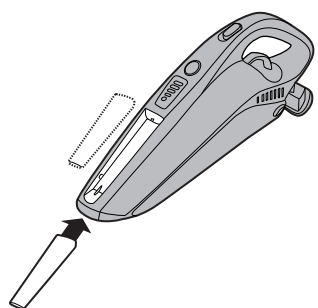
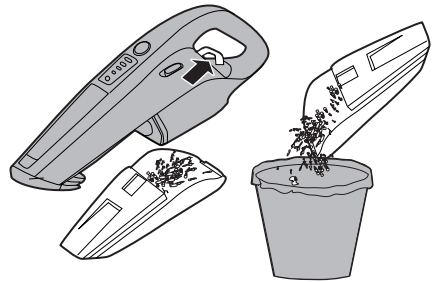
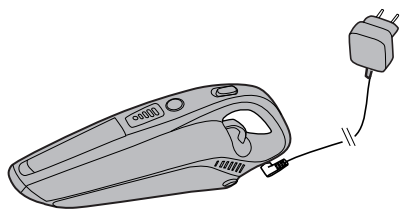
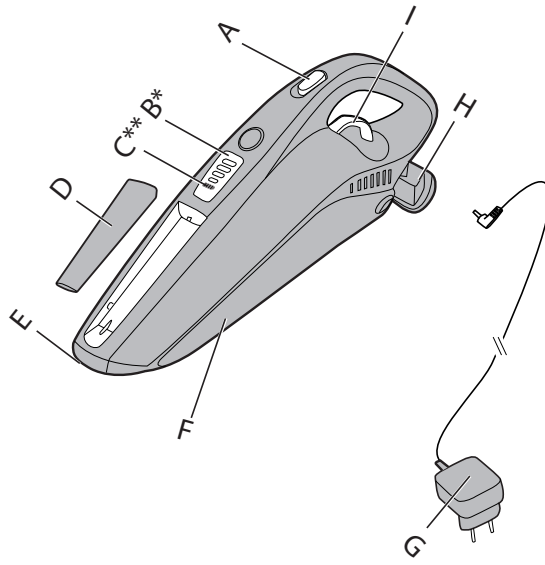



5

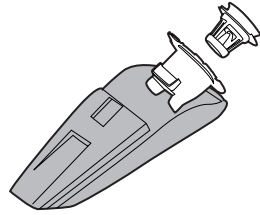

6

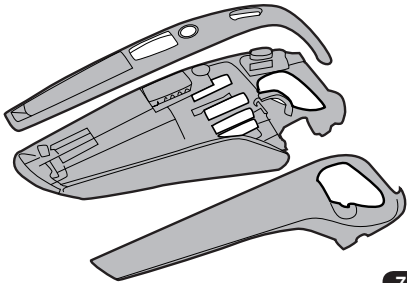

7

INSTRUCTIONS FOR SAFE USE

This appliance should only be used for domestic cleaning, as described in this user guide. Please ensure that this guide is fully understood before operating the appliance.

Always switch off and remove the charger from the socket before cleaning the appliance or any maintenance task.

This appliance can be used by children aged from 8 years and above and persons with reduced physical, sensory or mental capabilities or lack of experience and knowledge if they have been given supervision or instruction concerning use of the appliance in a safe way and understand the hazards involved. Children shall not play with the appliance. Cleaning and user maintenance shall not be made by children without supervision.

If the power cord is damaged stop using the appliance immediately. To avoid a safety hazard, an authorised Hoover service engineer must replace the power cord.

Never touch the charger with wet hands.

Use only the original charger supplied with the appliance.

Check that your supply voltage is the same as that stated on the charger.

Never charge the batteries in temperatures above 37°C or below 0°C.

This appliance is supplied with a double insulated battery charger which is only suitable for insertion in a 230V (UK 240V) socket outlet.

Plug the charger in to suitable socket outlet and connect the charger jack plug to the appliance. **[1]**

Ensure the product on/off switch button is at the "OFF" position while charging.

For the cleaner with LED Display*. The charging LED indicator** will flash to advise that the product is charging. When the product is fully charged, the icon will stop flashing and remain lit.

For the cleaner without LED Display*. The charging LED indicator** will illuminate red all the time to advise that the product is charging. When the product is fully charged, the red led will remain on.

Before first use, charge your cleaner for at least 24 hours. Do return the appliance to the charger base after use to recharge the batteries. If the operating time reduces after repeated use, let the cleaner run until it stops, then recharge for 24 hours and repeat this monthly for best results.

Re-connect the appliance to the charger after use to recharge the batteries.

It is normal for the charger to become warm to the touch when charging.

Use only attachments, consumables or spares recommended or supplied by Hoover.



Do not pick up hard or sharp objects, matches, hot ashes, cigarette ends or other similar items.

Do not spray with or pick up flammable liquids, cleaning fluids, aerosols or their vapours.

Do not continue to use your appliance or charger if it appears faulty.

Hoover service: To ensure the continued safe and efficient operation of this appliance we recommend that any servicing or repairs are only carried out by an authorised Hoover service engineer.

Do not use the appliance to clean animals or people.

Keep hands, feet, loose clothing and hair away from rotating brushes.

Do frequently clean the dust cup and filter assembly.

Do not unplug the charger by pulling on the power cord.

Unplug the charger in the event of prolonged absence (holidays, etc.). Recharge appliance again before use as batteries may self discharge over increased periods of storage.

Static electricity: Some carpets can cause a small build up of static electricity. Any static discharge is not hazardous to health.

Do not use your appliance out of doors.

Do not replace the batteries with non-rechargeable batteries.

Do not immerse the complete cleaner in liquids.

Do not run over the power cord when using your appliance.

End of Product Life Battery Disposal

If the appliance is to be disposed of the batteries must first be removed. The appliance must be disconnected from the supply mains when removing the battery. Dispose of the batteries safely. Used batteries should be taken to a recycling station and not disposed of with household waste. To remove the batteries, please contact the Hoover Customer Centre or proceed according to the following instructions.

IMPORTANT: Always fully discharge the batteries before removal.

Run the cleaner until the batteries are completely empty.

Remove top cover from the unit. Unscrew 5 screws and open the unit. Unscrew 6 screws and open the battery pack. Disconnect the cables and remove the batteries. Remove the wires which connect to the batteries one by one to make sure no short circuit.

NOTE: Should you experience any difficulty in dismantling the unit or for more detailed information on treatment, recovery and recycling of this appliance, please contact your local city office or your household waste disposal service.

FEATURES

- | | | | |
|---|--------------------------|---|-----------------------|
| A | On/Off Switch | F | Dust Cup |
| B | LED Display* | G | Charger |
| C | LED Charging Indicator** | H | Squeegee Tool |
| D | Removable Crevice Tool | I | Dust Cup Open Trigger |
| E | Suction Inlet | | |

CHARGING

Charging & LED Indicator**

1. Connect the charger to an ac wall outlet.
2. Connect the plug from the charger to the jack to charging socket. [1] Be sure the red light is on to indicate charging.
3. Before using the product disconnect the charger from the appliance and the ac outlet.

For the cleaner with LED Display *. The charging LED indicator** will flash to advise that the product is charging. When the product is fully charged, the icon will stop flashing and remain lit.

For the cleaner without LED Display *. The charging LED indicator** will illuminate red all the time to advise that the product is charging. When the product is fully charged, the red led will remain on.

NOTE: Use only the charger supplied with your cleaner to recharge the unit.

IMPORTANT: Before first use, charge your cleaner for at least 24 hours. When charging the cleaner, the power switch must be off. It is normal for the charger to become warm to the touch when charging. If the operating time reduces after repeated use, let the cleaner run until it stops, then recharge for 24 hours and repeat this monthly for best results. Never charge the batteries in temperatures above 37°C or below 0°C.

HOW TO USE

Push the switch to 'ON' position to begin cleaning and to turn off move the switch to the 'OFF' position. Empty and clean the unit and filter after each use or when the debris or liquid reaches the maximum fill line.

LED DISPLAY*

This cleaner is equipped with a LED display*. When the product is on, the display will report following information:

Battery Level Indicator*:

- 4 bars = 100% charge
- 3 bars = 75% charge
- 2 bars = 50% charge
- 1 bar = 25% charge
- 0 bar <= 5% charge

ATTACHMENTS

REMOVABLE CREVICE TOOL

Fit the crevice tool onto the dust cup to clean corners and hard to reach areas. [3]

WET PICK-UP

Fit the squeegee tool onto the dust cup to assist in collecting liquids. [4] Do not fill beyond the Max Line.

IMPORTANT: Always keep the cleaner vertical (nozzle end down) during and after collection of liquids, to prevent spillage or liquid entering the motor. Always empty the liquid out of the Container immediately after use. Do not pick up solvent based solutions, inflammable or combustible liquids. After picking up liquids, the Container, Deflector and Filter **MUST** be thoroughly dried and the squeegee removed before picking up dry dirt.

*certain models only ** May vary according to model

FILTER MAINTENANCE

CONTAINER & FILTER: REMOVAL and REPLACEMENT

IMPORTANT: FOR BEST RESULTS CLEAN THE DEFLECTOR AND FILTER AFTER EACH USE.

1. Holding the cleaner in vertical position, pull the trigger and remove Dust Cup. [5]
2. Gently remove Filter and Deflector. [6]
3. Empty the container, brush the dust and dirt off the filters. [2]
4. The container, deflector and Filter may be washed in warm soapy water. Make sure all are completely dry before replacing in your cleaner.
5. Replace the filter into the dust container and re-assemble the dust container to the cleaner.

End of Product Life Battery Disposal

If the cleaner is to be disposed of the batteries should be removed. Used batteries should be taken to a recycling station and not disposed with household waste.

IMPORTANT: Always fully discharge the batteries before removal.

Battery removal

Remove top cover from the unit. Unscrew 5 screws and open the unit. Unscrew 6 screws and open the battery pack. Disconnect the cables and remove the batteries. [7]

Note: Should you experience any difficulties in dismantling the unit or for more detailed information about treatment, recovery and recycling of this product, please contact your local city office, your household waste disposal service.

IMPORTANT INFORMATION

Hoover spares and Consumables

Always replace parts with genuine Hoover spares. These are available from your local Hoover dealer or direct from Hoover. When ordering parts always quote your model number.

Wet&Dry Filter S102 35601644

The Environment:

The symbol on the product indicates that this product may not be treated as household waste. Instead it shall be handed over to the appliance collection point for recycling of electrical and electronic equipment. Disposal must be carried out in accordance with the local environmental regulations for waste disposal. For more detailed information about treatment, recovery and recycling of this product, please contact your local city office, your household waste disposal service or the shop where you purchased the product.



This product complies with the European Directives 2014/35/EU, 2014/30/EU and 2011/65/EU.

HOOVER Limited Pentrebach, Merthyr Tydfil, Mid Glamorgan CF48 4TU

YOUR GUARANTEE

The guarantee conditions for this appliance are as defined by our representative in the country in which it is sold. Details regarding these conditions can be obtained from the dealer from whom the appliance was purchased. The bill of sale or receipt must be produced when making any claim under the terms of this guarantee.

Subject to change without notice.



®

BORN INNOVATIVE

PRINTED IN P.R.C
48021233