

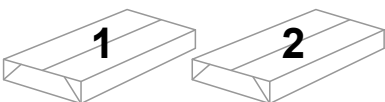

SLBT1290 / SLBT1790

SLAB 25 DINING TABLE

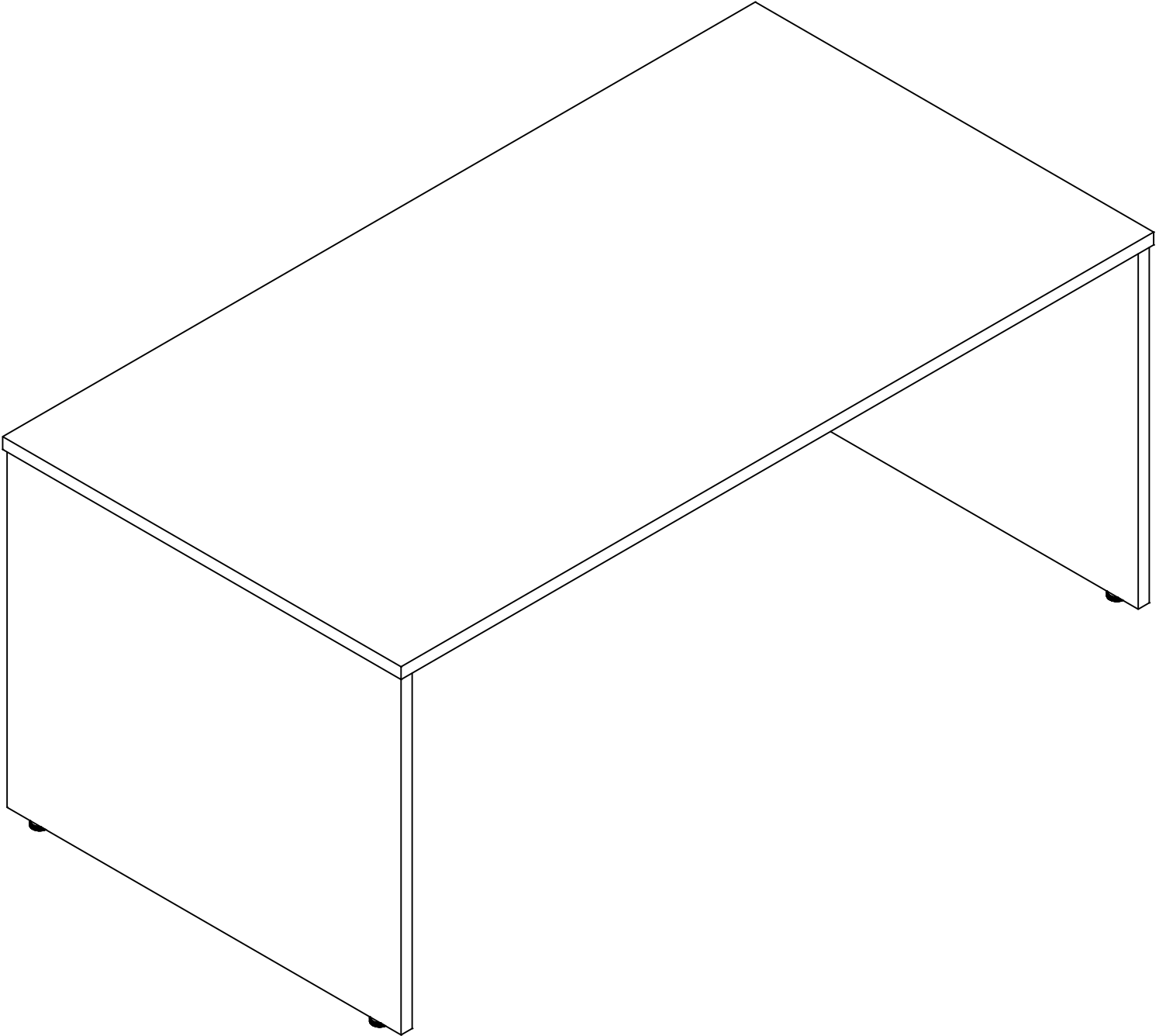

**TOOLS REQUIRED
FOR ASSEMBLY**

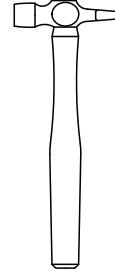
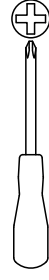
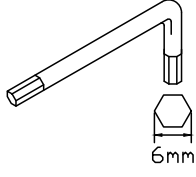
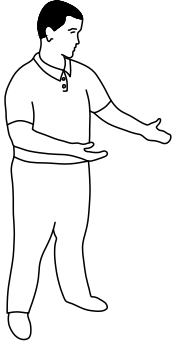

**DONT STRUGGLE
2 MAN LIFT**

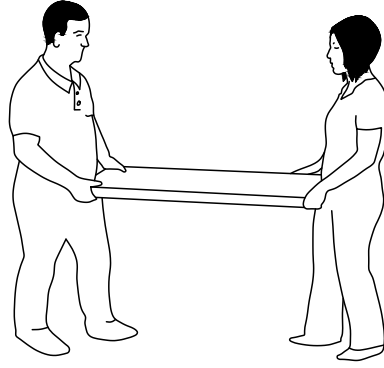
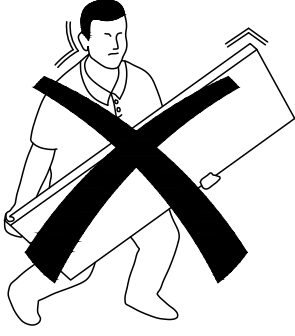

**ALWAYS HANDLE
ITEMS WITH CARE**

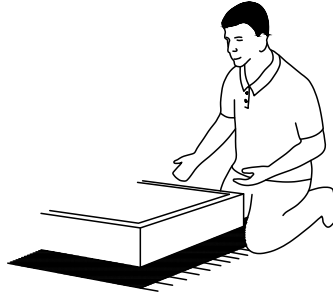
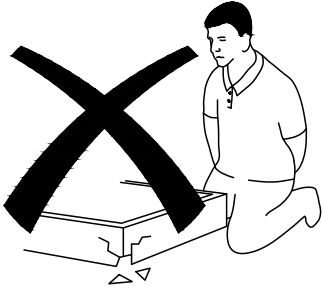

**IF UNSURE CALL
FOR ASSISTANCE**

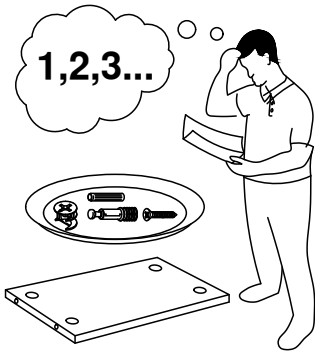

**KEEP FITTINGS AWAY
FROM CHILDREN**

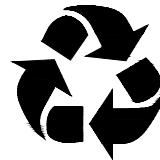
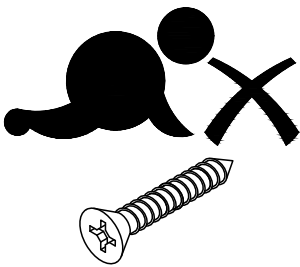



Please check that you have all the panels!

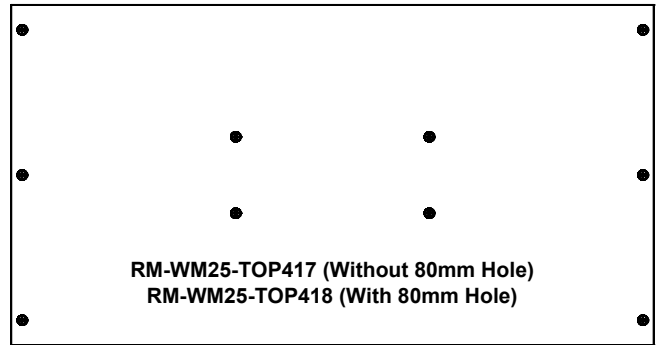
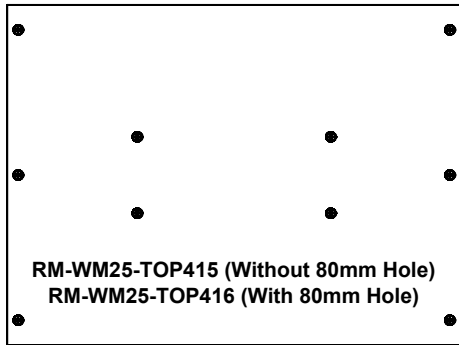

OR

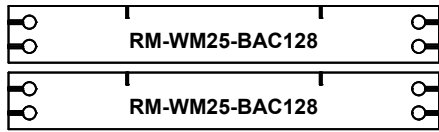

1200mm TABLE

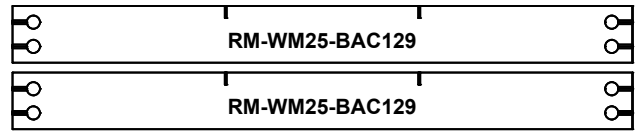

1700mm TABLE

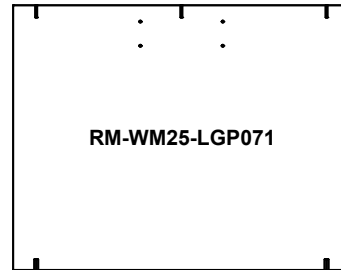
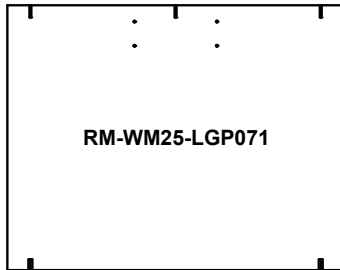

Please check that you have all the hardware!

QUANTITY - 10



Furniture Connector Pin
RM-PIN01

QUANTITY - 8



35mm Maxifix Cam

QUANTITY - 8

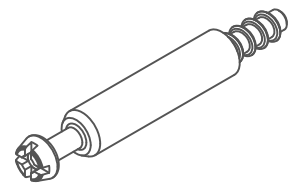

55mm Maxifix Pin

QUANTITY - 4

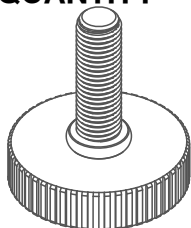

M8 Low Profile Adjustable Foot
RM-FRL36

QUANTITY - 4



M8 Gesipa Insert
RM-NUT04

QUANTITY - 1

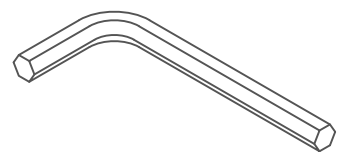

6mm Allen Key

1

Step 1
Insert the maxifix cams into the pre drilled holes on the support brace. The cam should be inserted as per diagram A. Repeat for both braces.

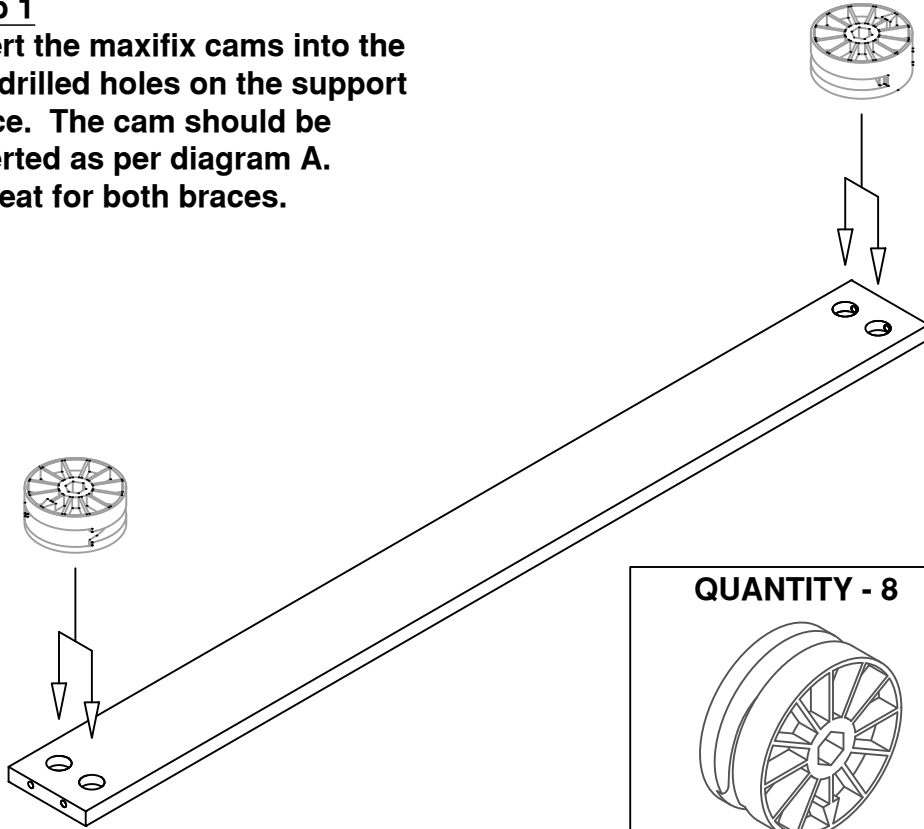

35mm Maxifix Cam

Diagram A

Ensure the arrow on this fitting is aligned with the hole that is drilled on the edge of the panel.

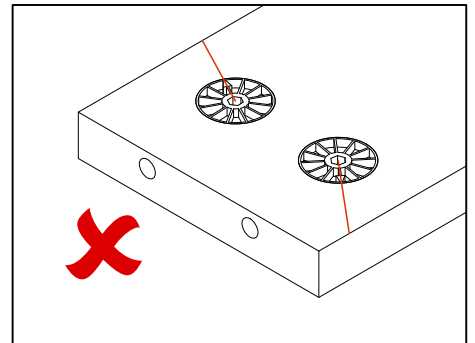
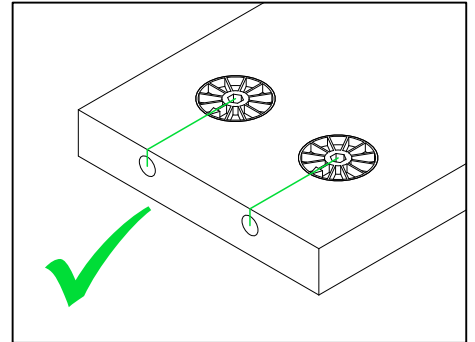
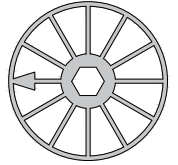

2

Step 2
Screw in the connector pins into the pre drilled holes on the panel. Ensure the screw is inserted correctly as per diagram B. Repeat for both braces.

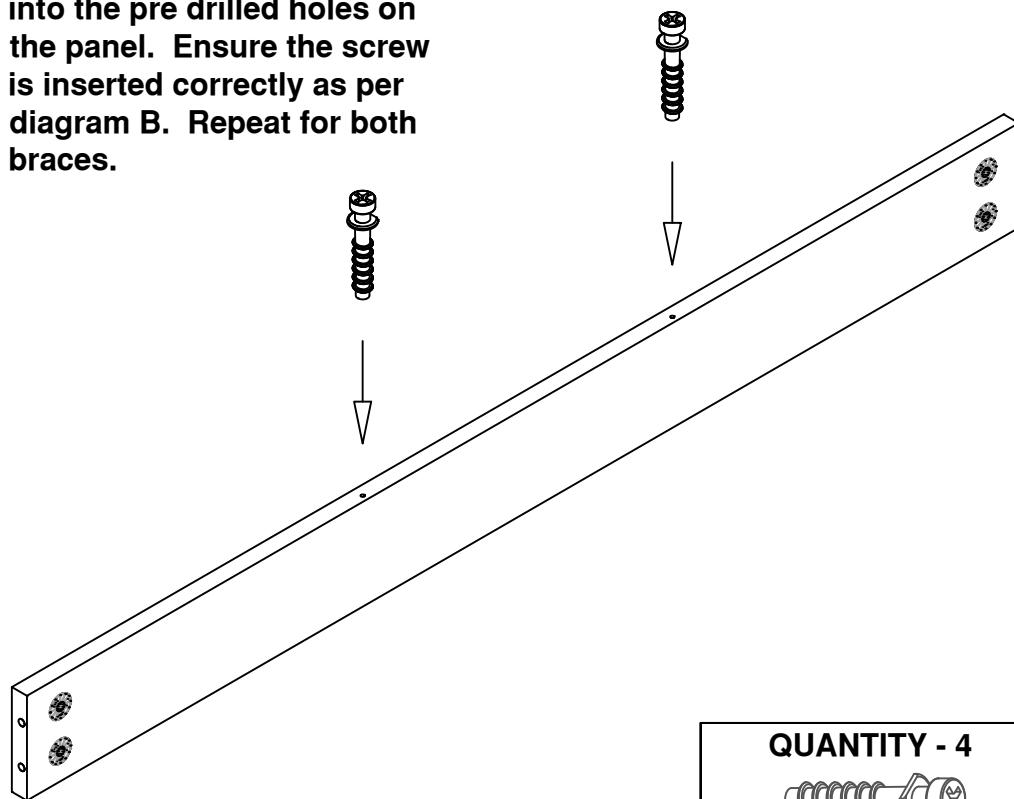

Furniture Connector Pin Diagram B

Ensure this pin is correctly inserted into the panel. The flat rim of this pin should sit against the edge of the panel.

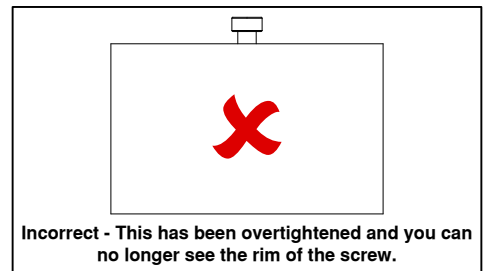

Incorrect - This has been overtightened and you can no longer see the rim of the screw.

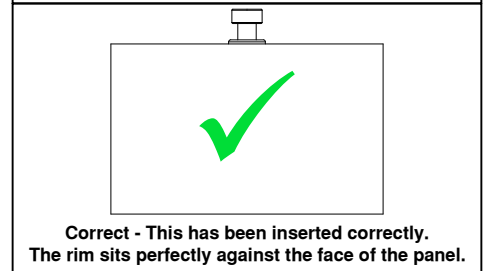

Correct - This has been inserted correctly. The rim sits perfectly against the face of the panel.

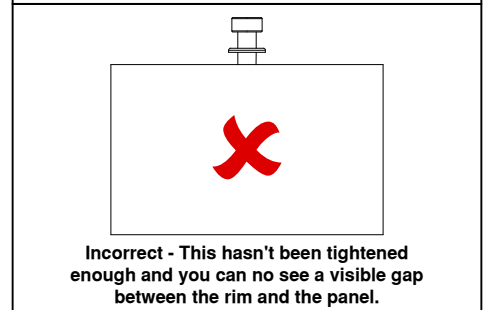
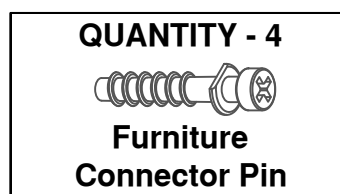

Incorrect - This hasn't been tightened enough and you can no see a visible gap between the rim and the panel.

4

3

Step 3
Knock in the gesipa inserts
into the holes on the bottom
edge of the leg.
Repeat for both legs.

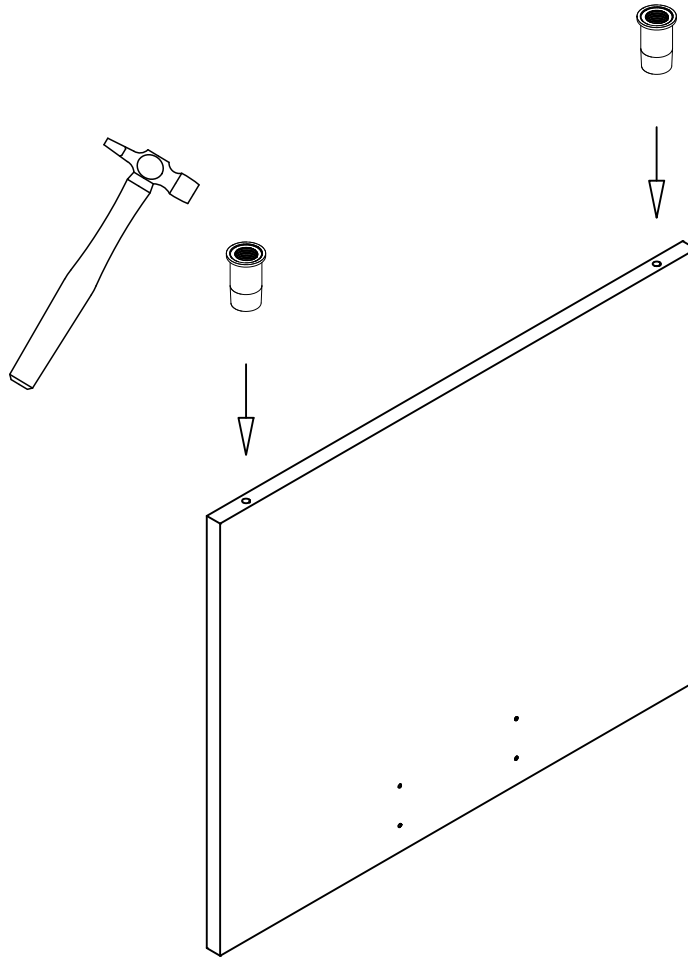

QUANTITY - 4

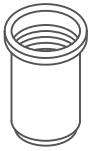

M8 Gesipa Insert
RM-NUT04

4

Step 4
Screw the adjustable feet
into the bottom of the leg panel.
Repeat for both legs.

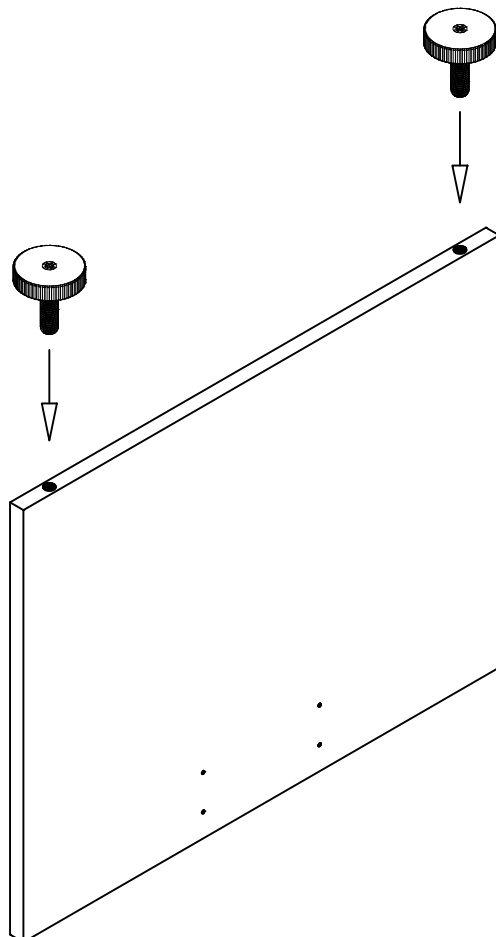

QUANTITY - 4

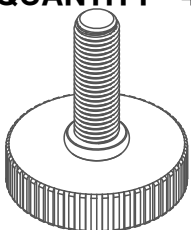

M8 Low Profile Adjustable Foot
RM-FRL36

5

Step 5
Screw in the connector pins into the pre drilled holes on the leg panel. Ensure the screw is inserted correctly as per diagram C. Repeat for both legs.

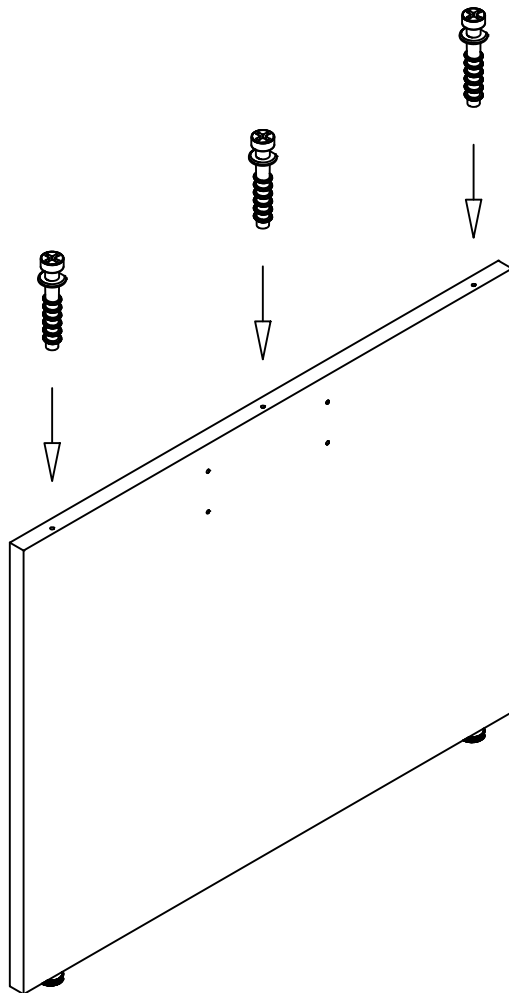

Furniture Connector Pin Diagram C

Ensure this pin is correctly inserted into the panel. The flat rim of this pin should sit against the edge of the panel.

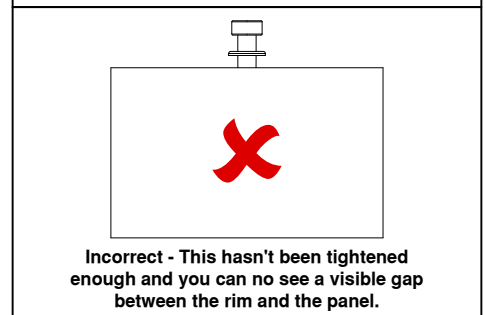
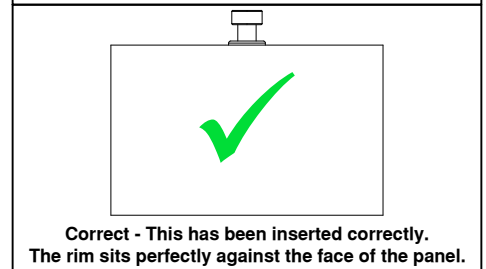
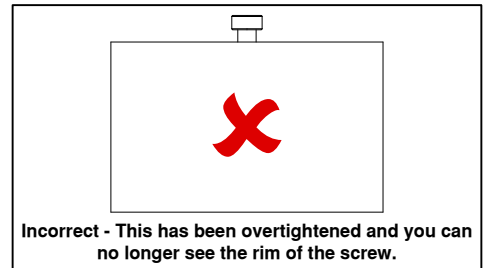

QUANTITY - 6



Furniture Connector Pin

6

Step 6
Screw the maxifix pins into the pre drilled holes on the leg panels, ensure they are screwed in fully so no thread is left visible. Repeat for both legs.

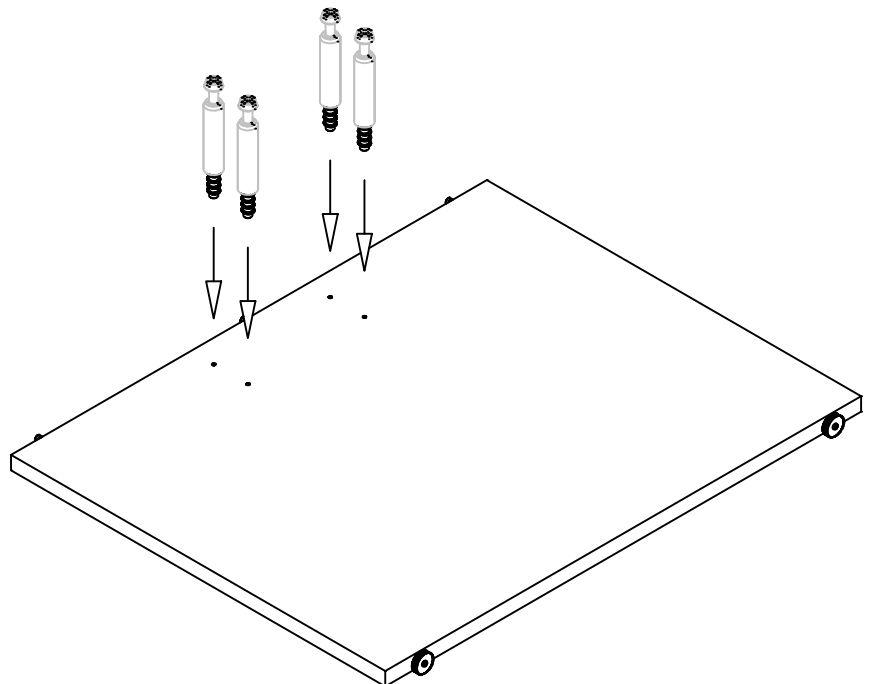

QUANTITY - 8

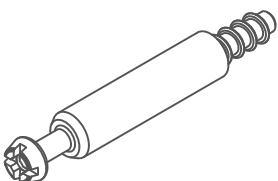

55mm Maxifix Pin

6

7

Step 7

Slide the braces onto the leg panel ensuring that the cam fittings engage over the maxifix pins. Once in place tighten the cams using the 6mm allen key that has been provided to lock the braces into place.

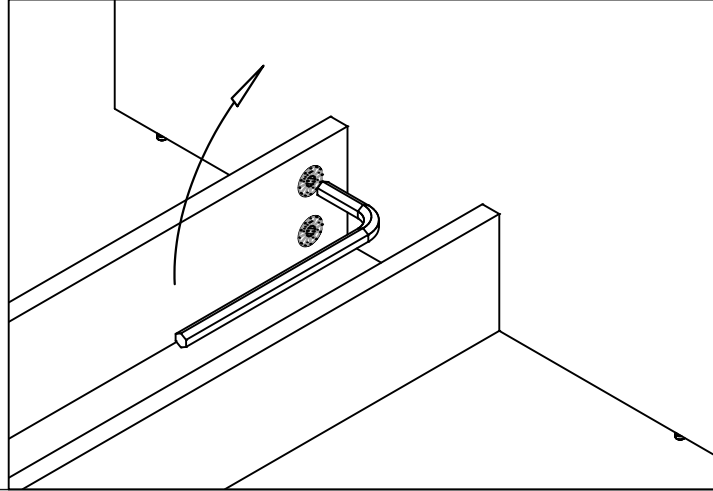
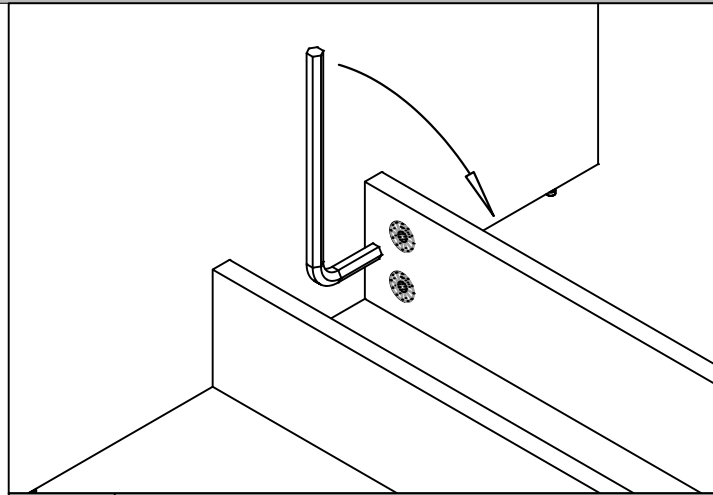
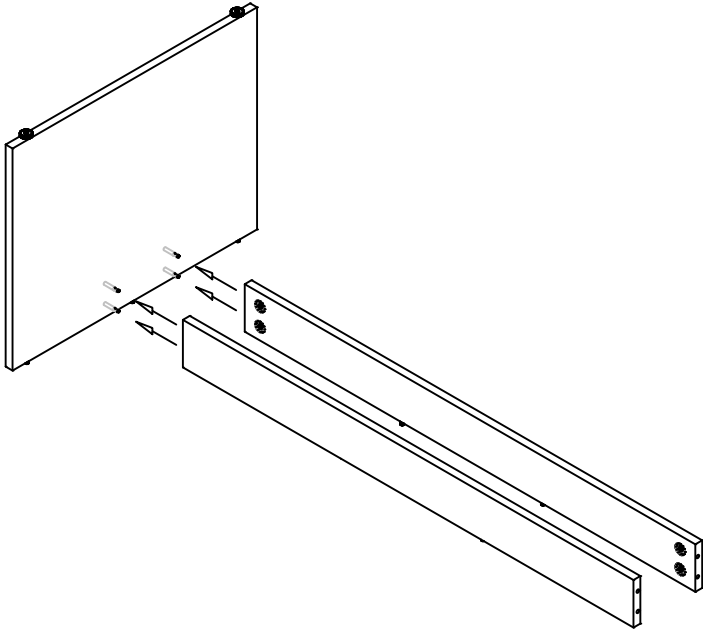

8

Step 8

Slide the remaining leg onto the part assembled frame ensuring that the maxifix pins engage into the maxifix cams. Once in place tighten the cams using the 6mm allen key that has been provided to lock the braces into place.

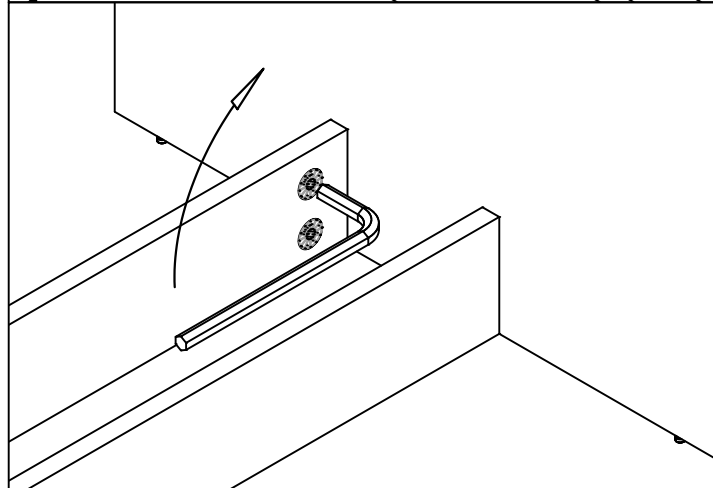
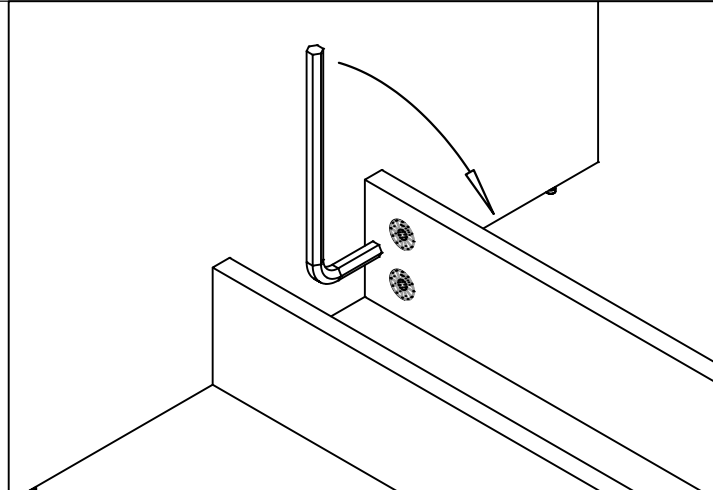
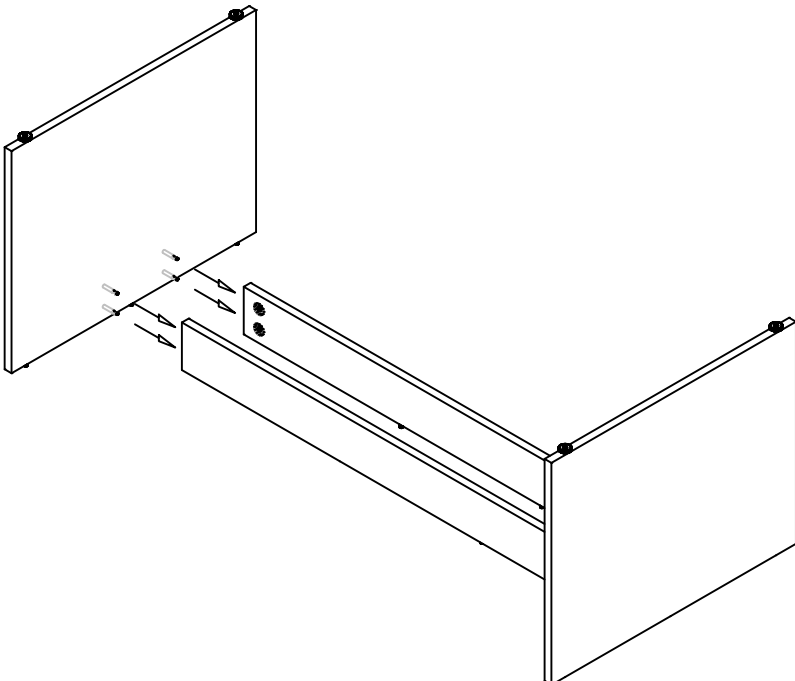

9

Step 9

Place your table top face down onto a clean dry surface and place the assembled frame onto the top ensuring all fittings in the frame engage into the furniture connectors that are pre inserted in the table top.

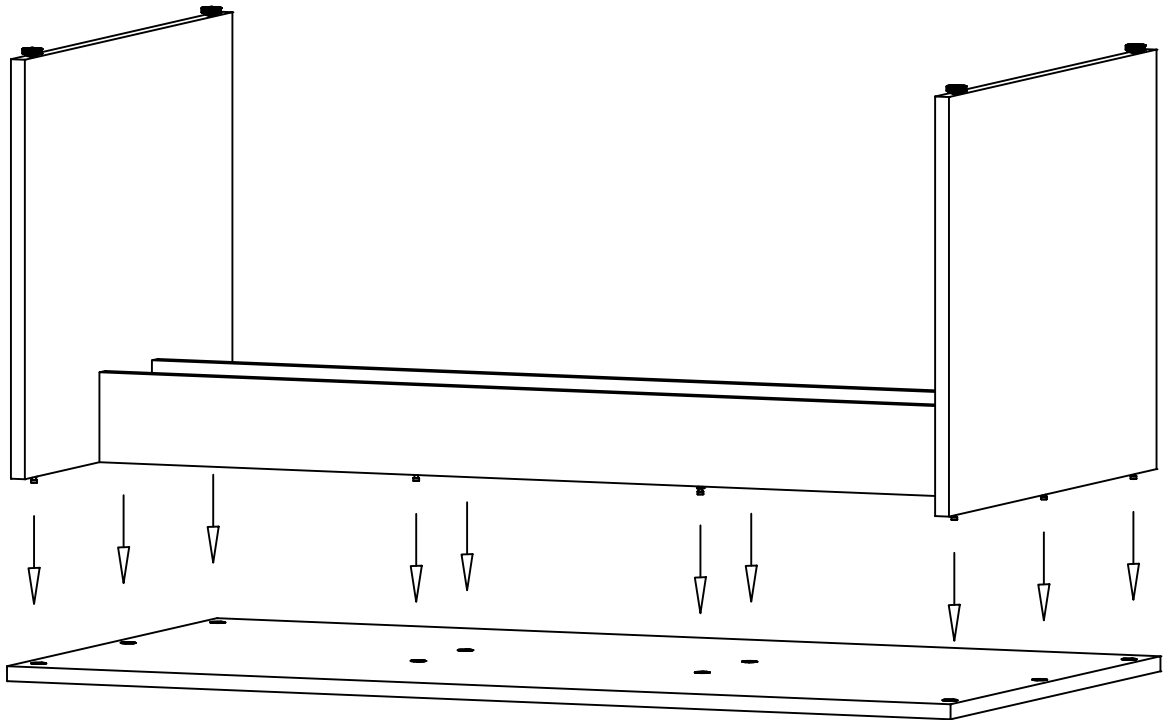

10

Step 10

Once in position fully tighten all furniture connectors, use a pozi drive screwdriver turning the cams in a clockwise direction.

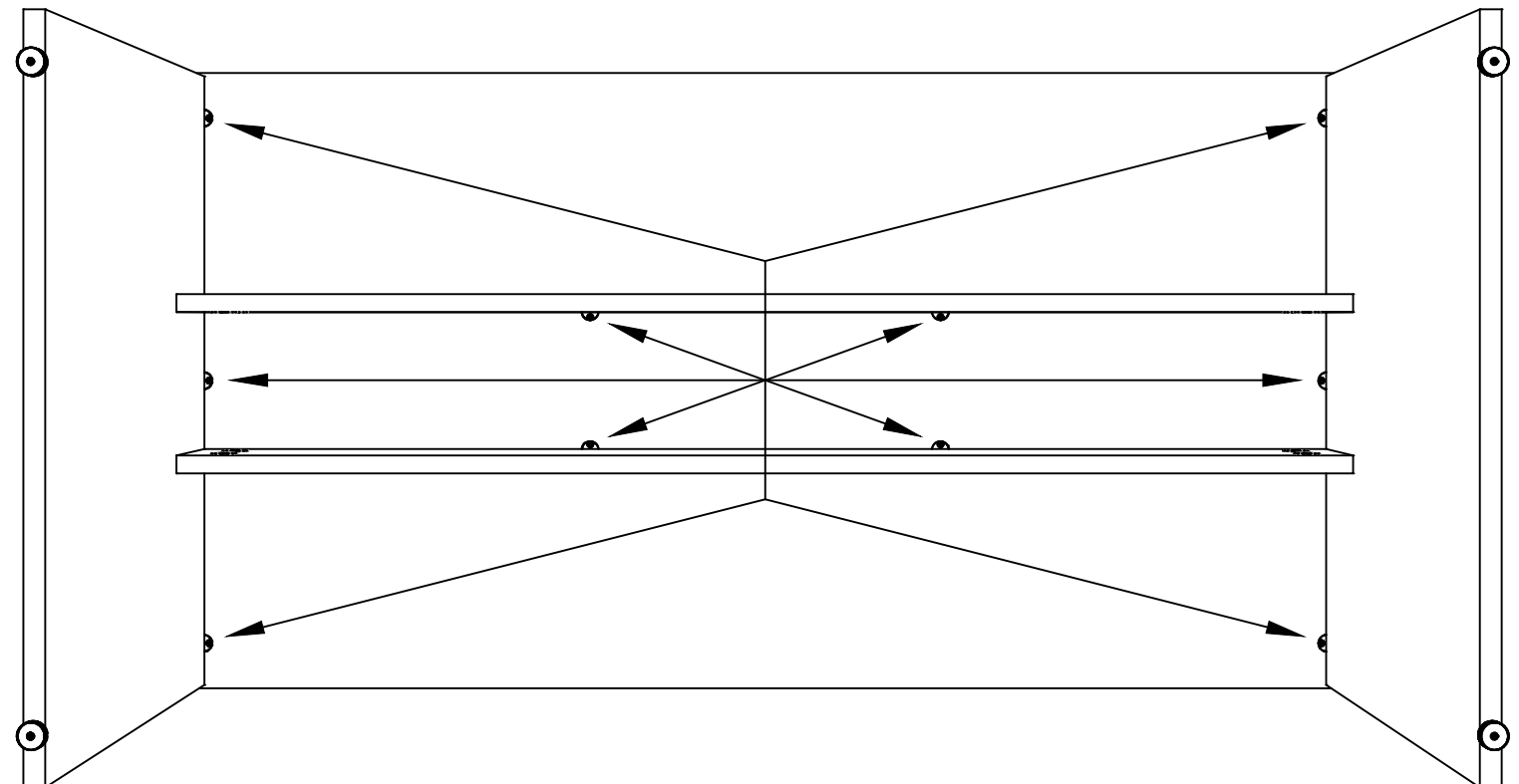

8



SLBB1100 / SLBB1500

SLAB 25 DINING BENCH

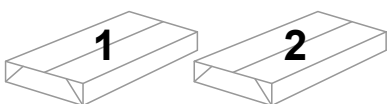
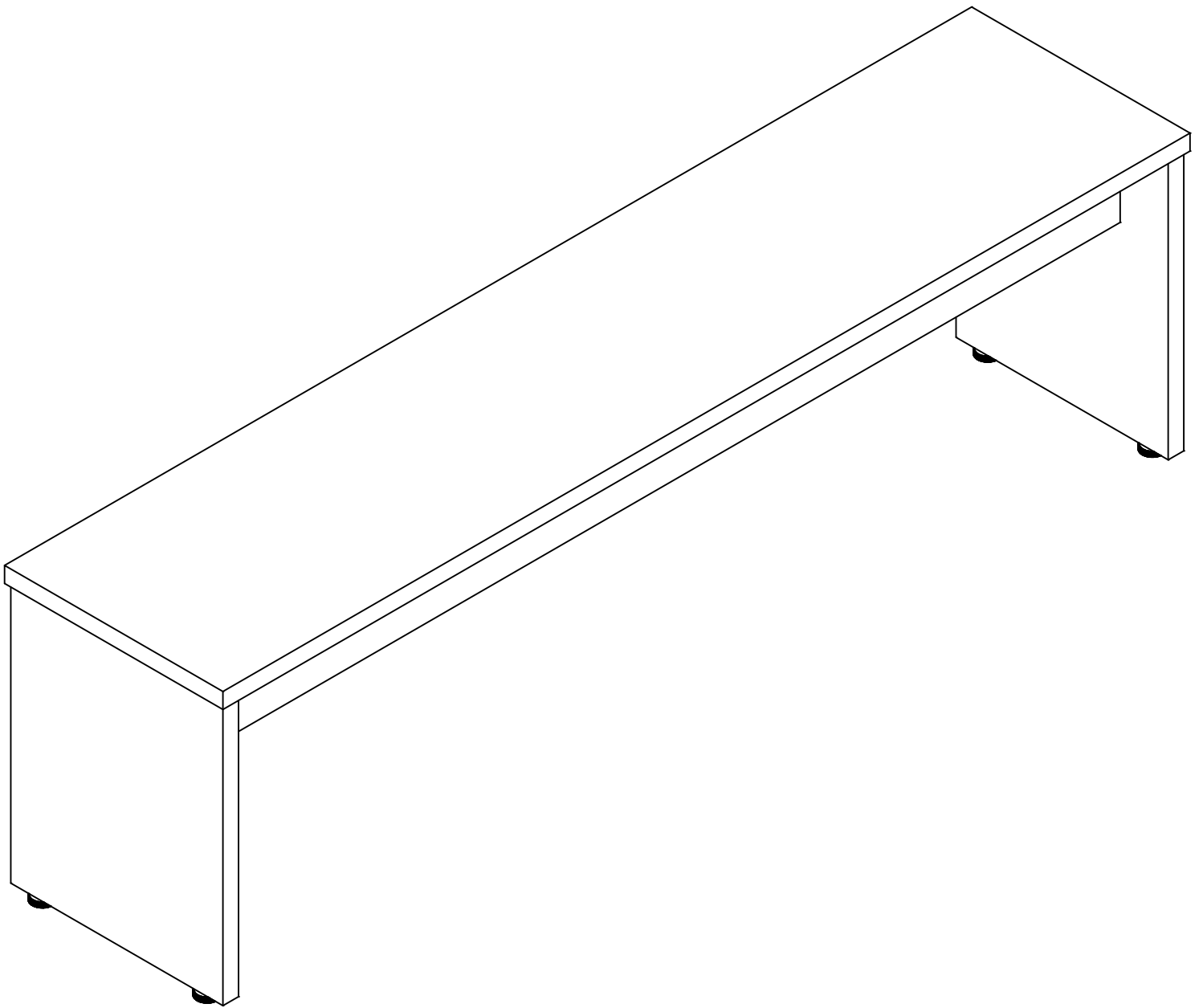

**TOOLS REQUIRED
FOR ASSEMBLY**

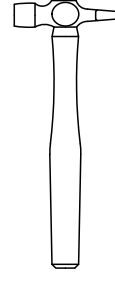
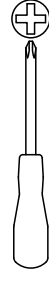
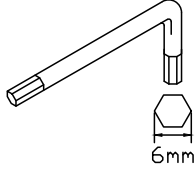
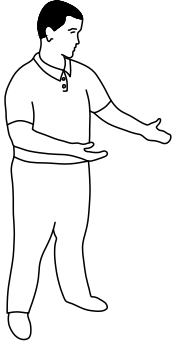

**DONT STRUGGLE
2 MAN LIFT**

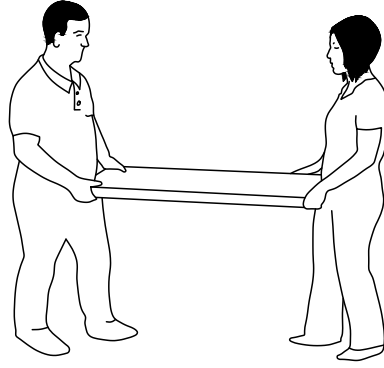
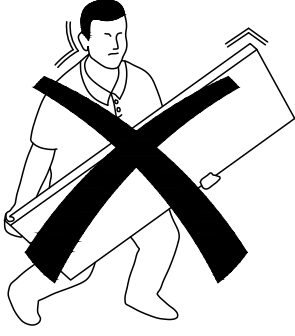

**ALWAYS HANDLE
ITEMS WITH CARE**

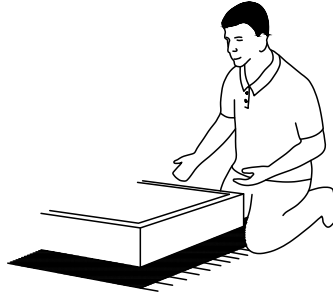
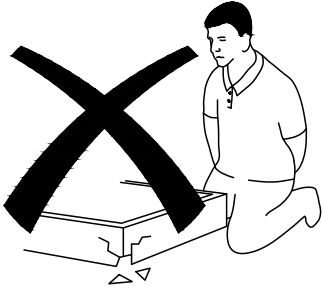

**IF UNSURE CALL
FOR ASSISTANCE**

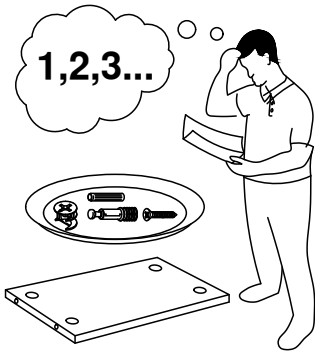

**KEEP FITTINGS AWAY
FROM CHILDREN**

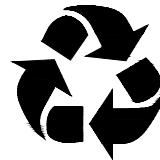
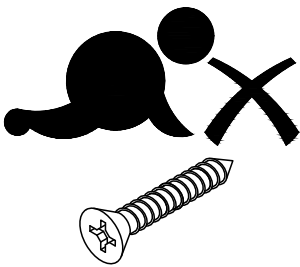



Please check that you have all the panels!



OR

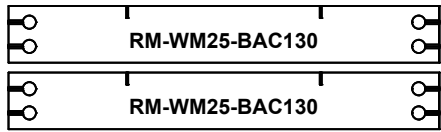
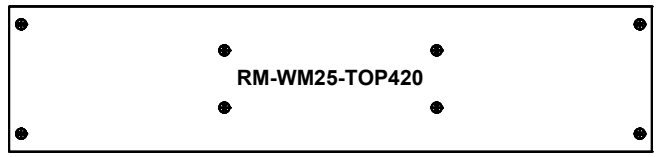

1050mm BENCH

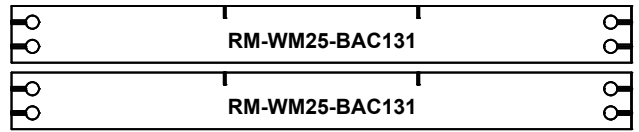

1550mm BENCH

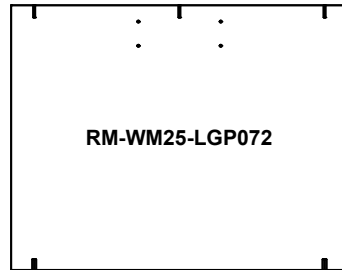
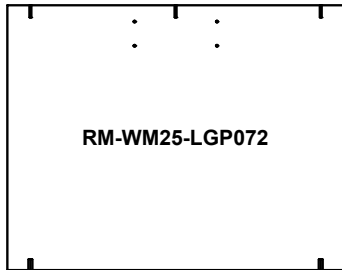

Please check that you have all the hardware!

QUANTITY - 8



**Furniture Connector Pin
RM-PIN01**

QUANTITY - 8



35mm Maxifix Cam

QUANTITY - 8

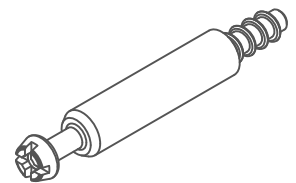

55mm Maxifix Pin

QUANTITY - 4

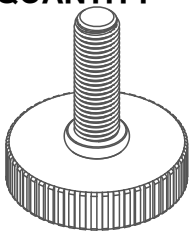

**M8 Low Profile Adjustable Foot
RM-FRL36**

QUANTITY - 4



**M8 Gesipa Insert
RM-NUT04**

QUANTITY - 1

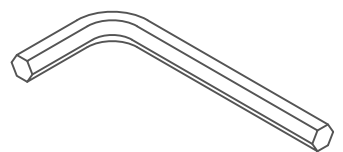

6mm Allen Key

1

Step 1
Insert the maxifix cams into the pre drilled holes on the support brace. The cam should be inserted as per diagram A. Repeat for both braces.

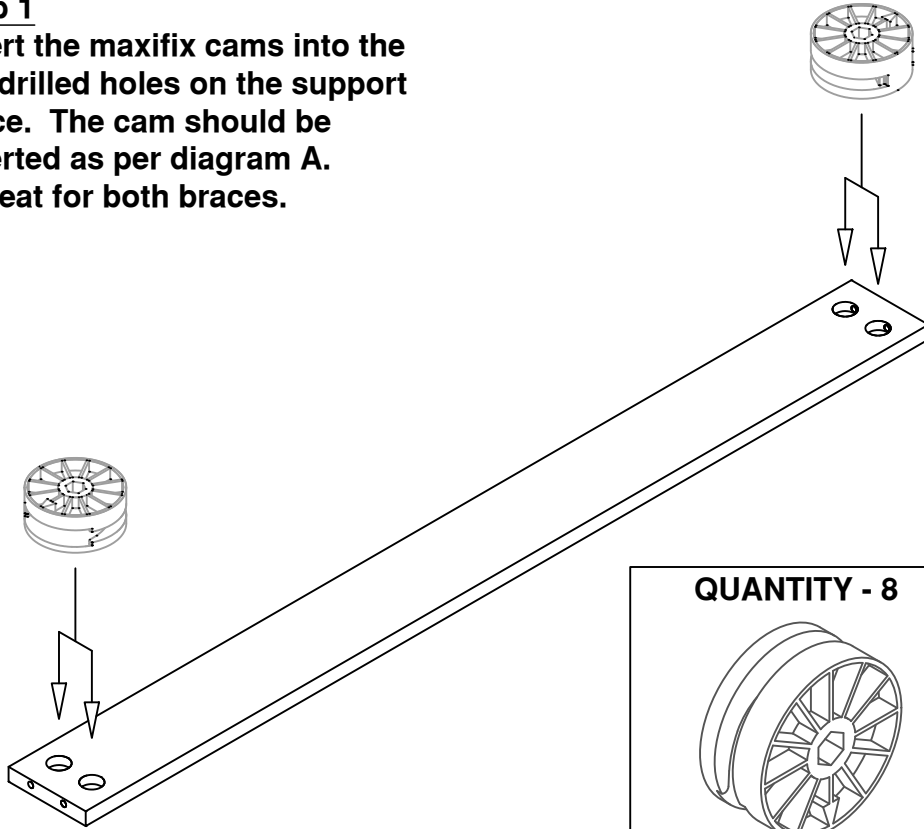

35mm Maxifix Cam

Diagram A

Ensure the arrow on this fitting is aligned with the hole that is drilled on the edge of the panel.

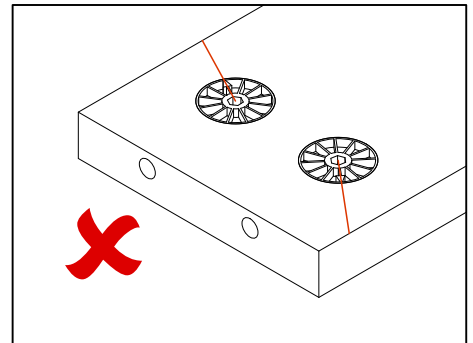
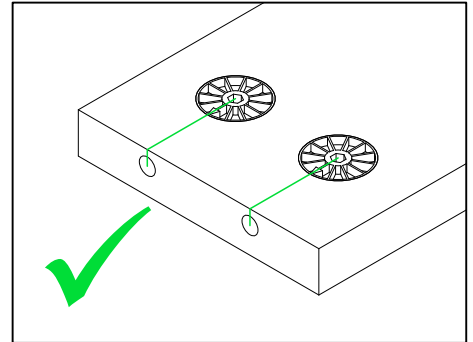
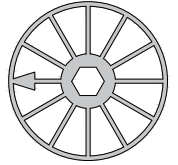

QUANTITY - 8



35mm Maxifix Cam

2

Step 2
Screw in the connector pins into the pre drilled holes on the panel. Ensure the screw is inserted correctly as per diagram B. Repeat for both braces.

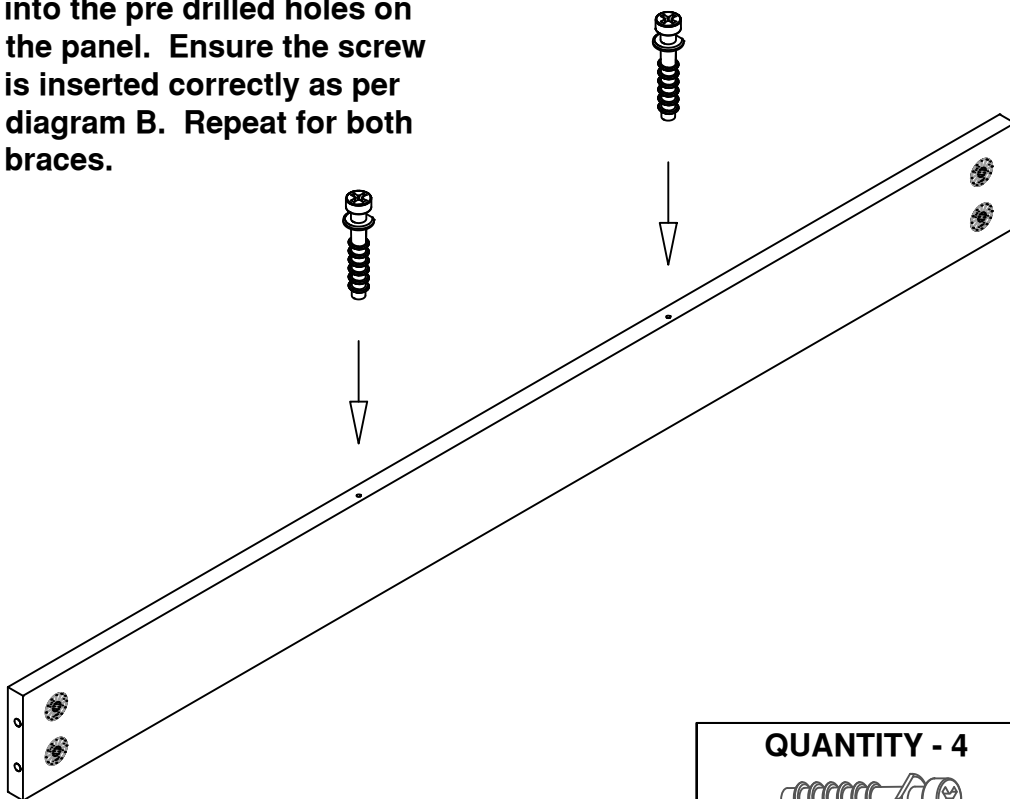

Furniture Connector Pin **Diagram B**

Ensure this pin is correctly inserted into the panel. The flat rim of this pin should sit against the edge of the panel.

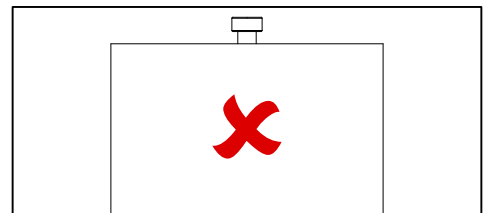

Incorrect - This has been overtightened and you can no longer see the rim of the screw.

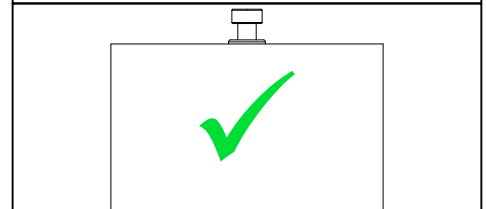

Correct - This has been inserted correctly. The rim sits perfectly against the face of the panel.

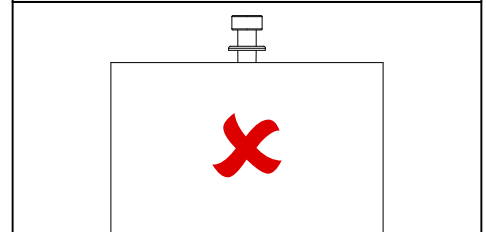

Incorrect - This hasn't been tightened enough and you can no see a visible gap between the rim and the panel.

QUANTITY - 4



Furniture Connector Pin

4

3

Step 3
Knock in the gesipa inserts
into the holes on the bottom
edge of the leg.
Repeat for both legs.

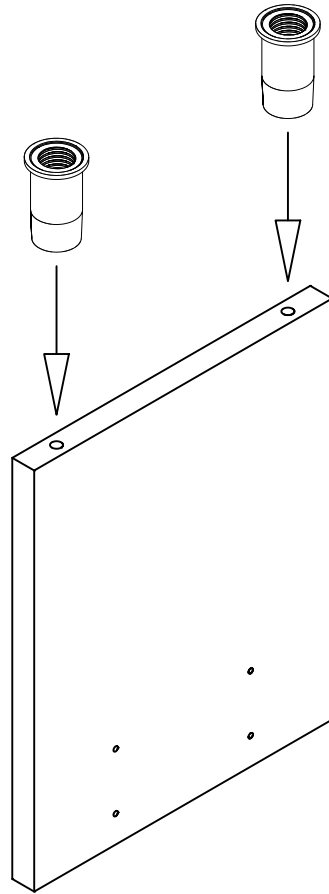
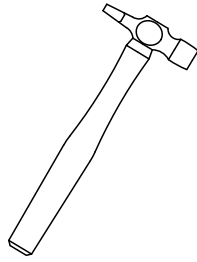

QUANTITY - 4

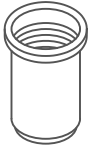

M8 Gesipa Insert
RM-NUT04

4

Step 4
Screw the adjustable feet
into the bottom of the leg panel.
Repeat for both legs.

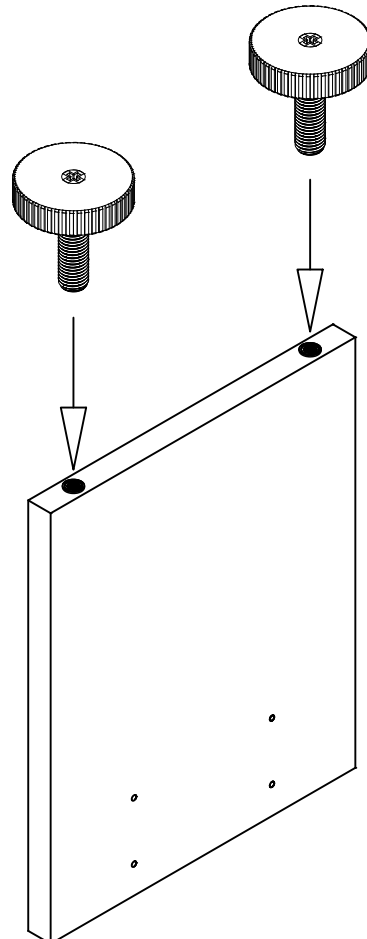

QUANTITY - 4

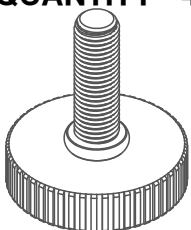

M8 Low Profile Adjustable Foot
RM-FRL36

5

Step 5
Screw in the connector pins into the pre drilled holes on the leg panel. Ensure the screw is inserted correctly as per diagram C. Repeat for both legs.

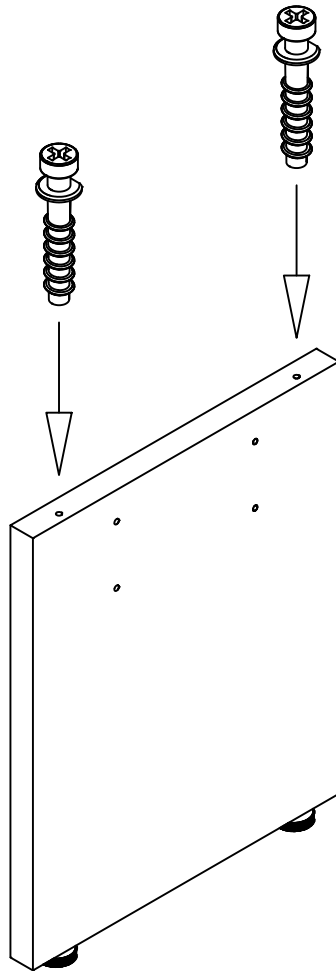

QUANTITY - 4



**Furniture
Connector Pin**

Furniture Connector Pin Diagram C

Ensure this pin is correctly inserted into the panel. The flat rim of this pin should sit against the edge of the panel.

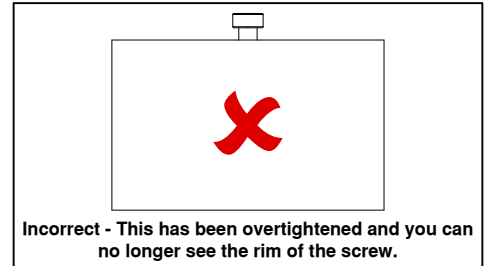

Incorrect - This has been overtightened and you can no longer see the rim of the screw.

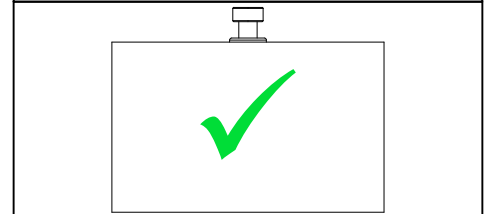

Correct - This has been inserted correctly. The rim sits perfectly against the face of the panel.

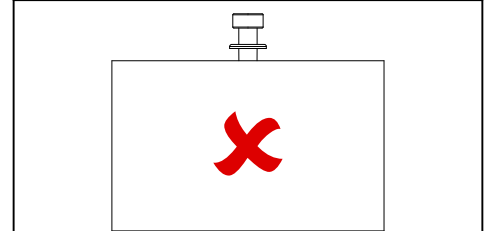

Incorrect - This hasn't been tightened enough and you can see a visible gap between the rim and the panel.

6

Step 6
Screw the maxifix pins into the pre drilled holes on the leg panels, ensure they are screwed in fully so no thread is left visible. Repeat for both legs.

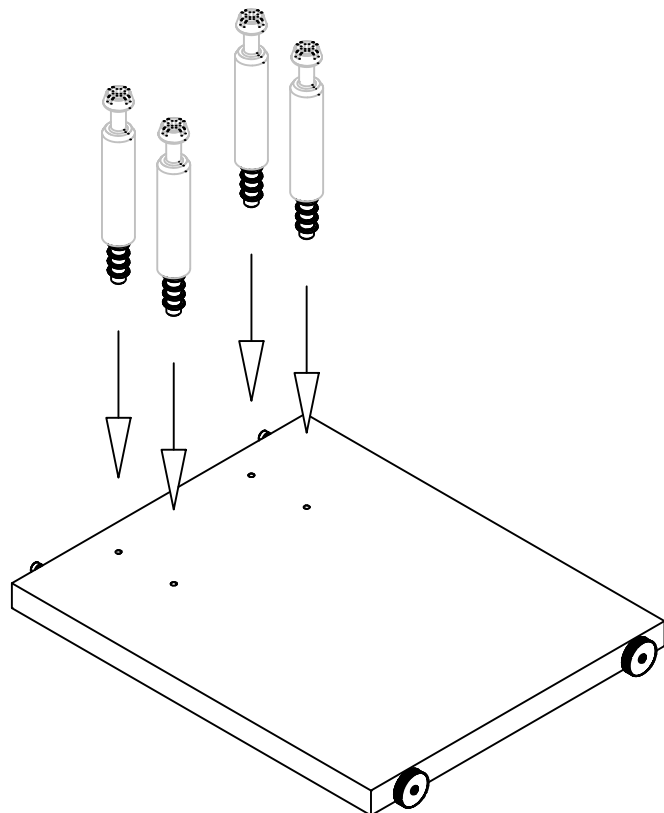

QUANTITY - 8

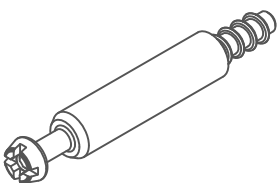

55mm Maxifix Pin

6

7

Step 7

Slide the braces onto the leg panel ensuring that the cam fittings engage over the maxifix pins. Once in place tighten the cams using the 6mm allen key that has been provided to lock the braces into place.

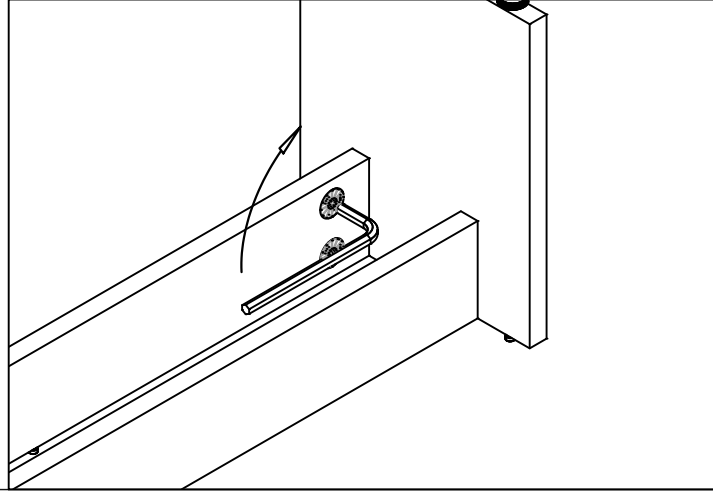
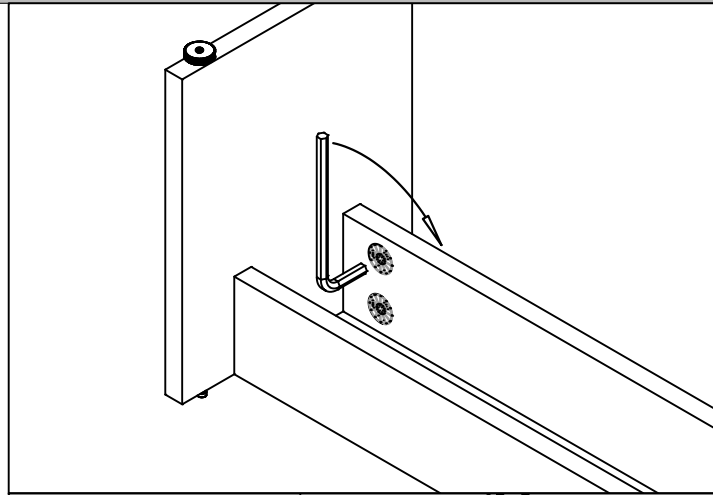
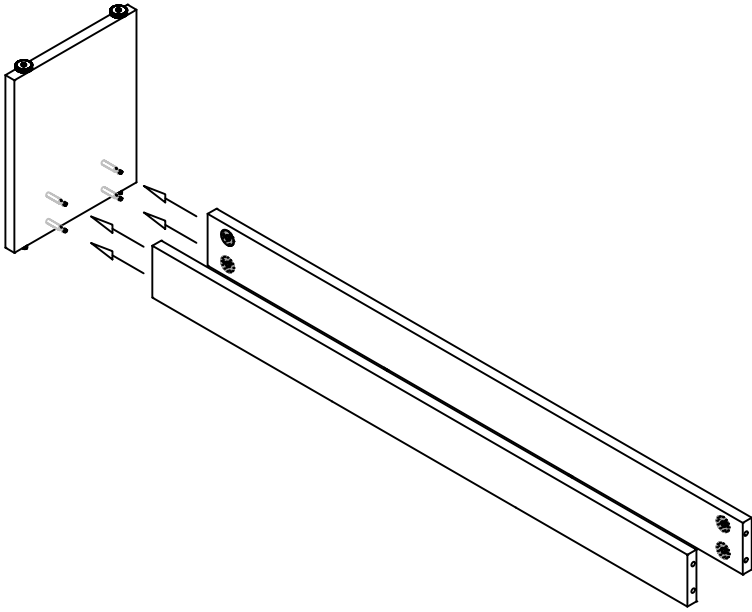

8

Step 8

Slide the remaining leg onto the part assembled frame ensuring that the maxifix pins engage into the maxifix cams. Once in place tighten the cams using the 6mm allen key that has been provided to lock the braces into place.

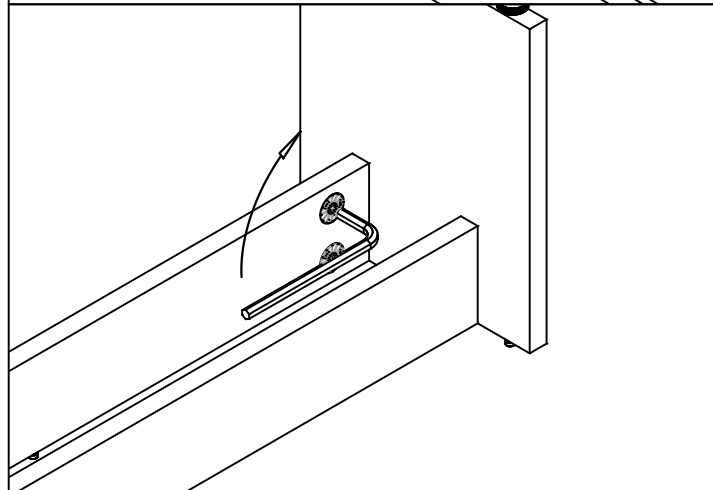
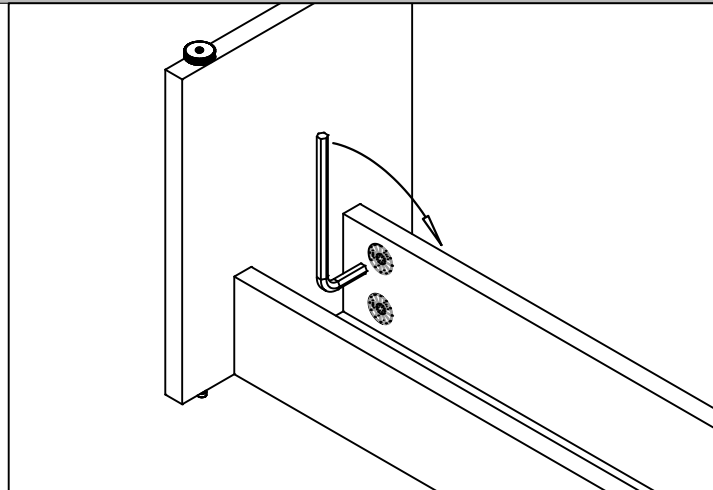
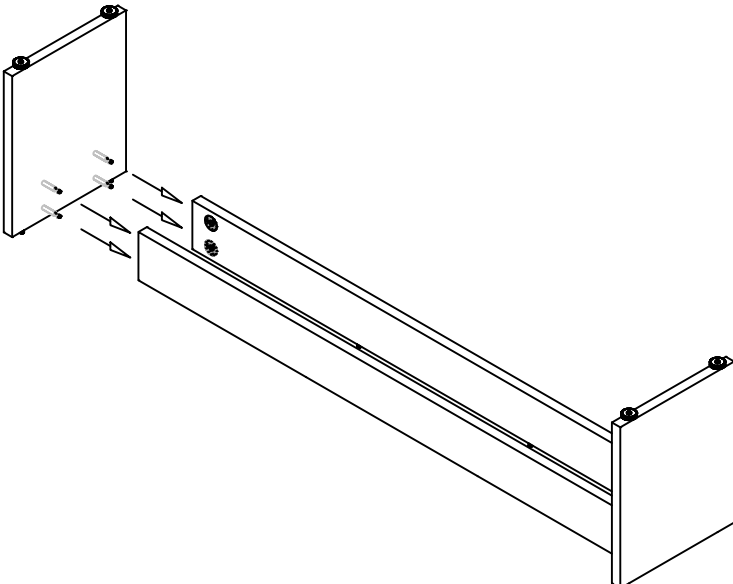

9

Step 9

Place the bench top face down onto a clean dry surface and place the assembled frame onto the top ensuring all fittings in the frame engage into the furniture connectors that are pre inserted in the top.

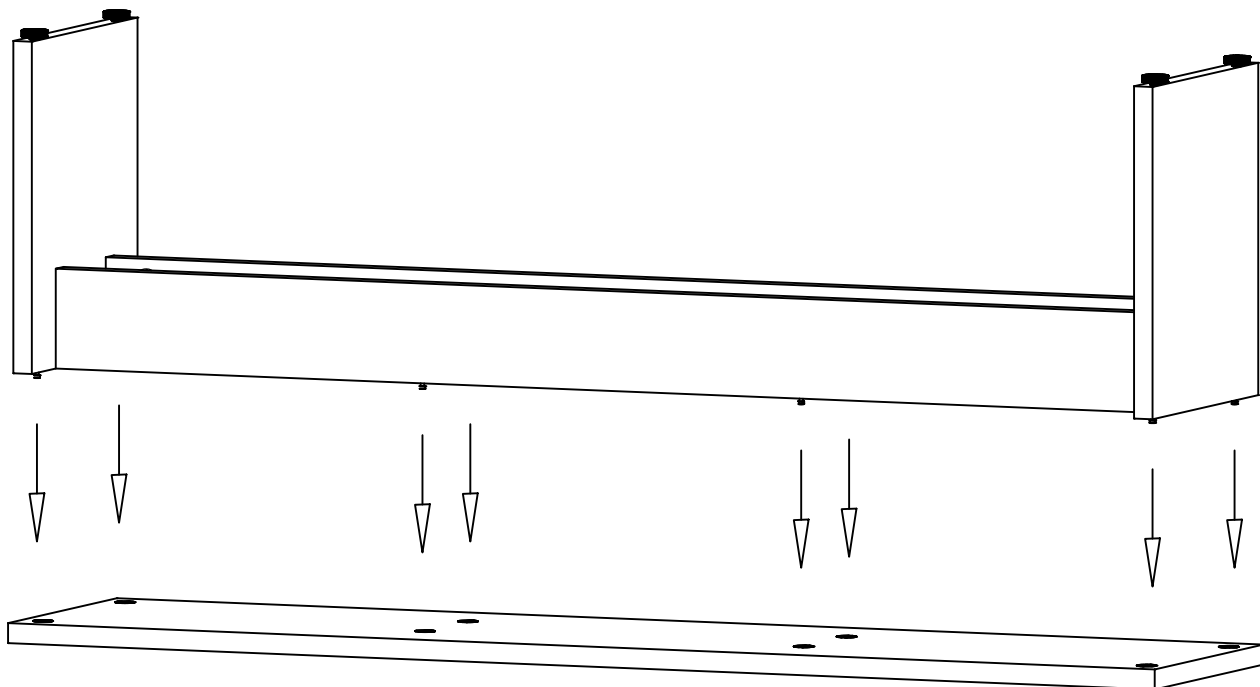

10

Step 10

Once in position fully tighten all furniture connectors, use a pozi drive screwdriver turning the cams in a clockwise direction.

