

MSWL LH Wave Desk

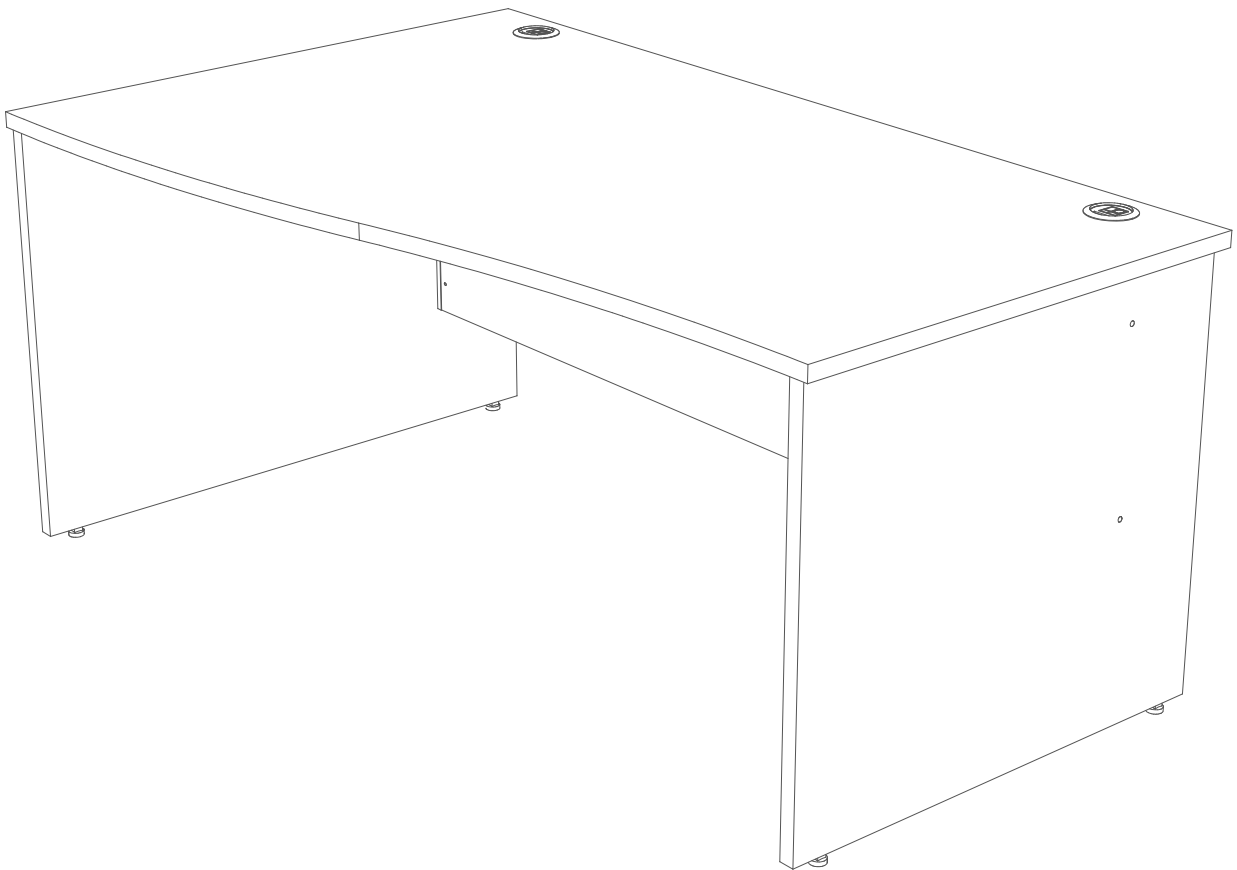

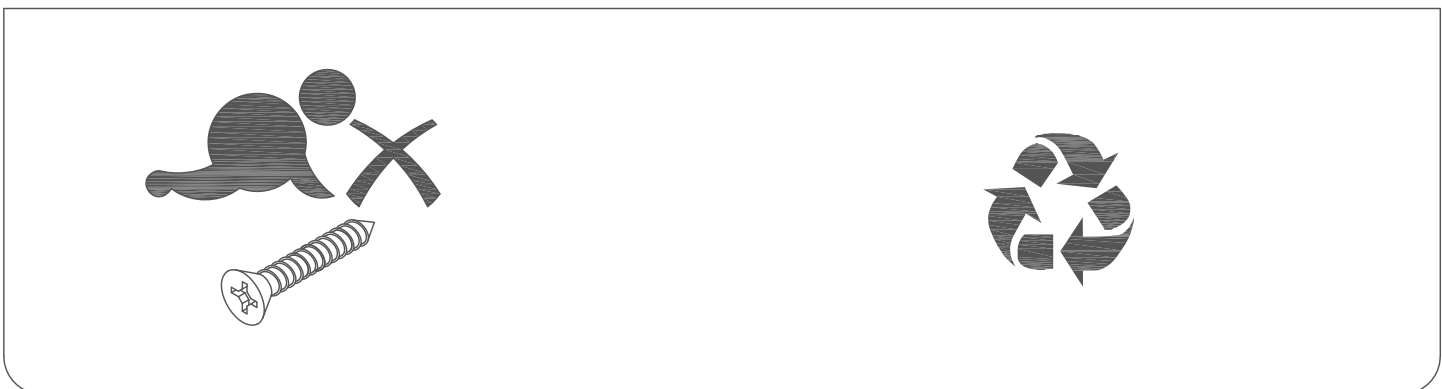

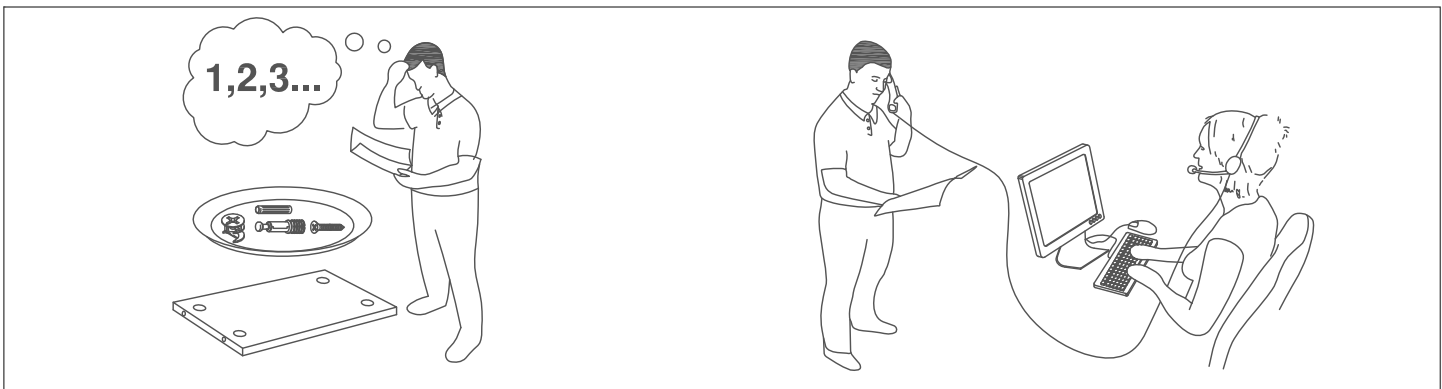
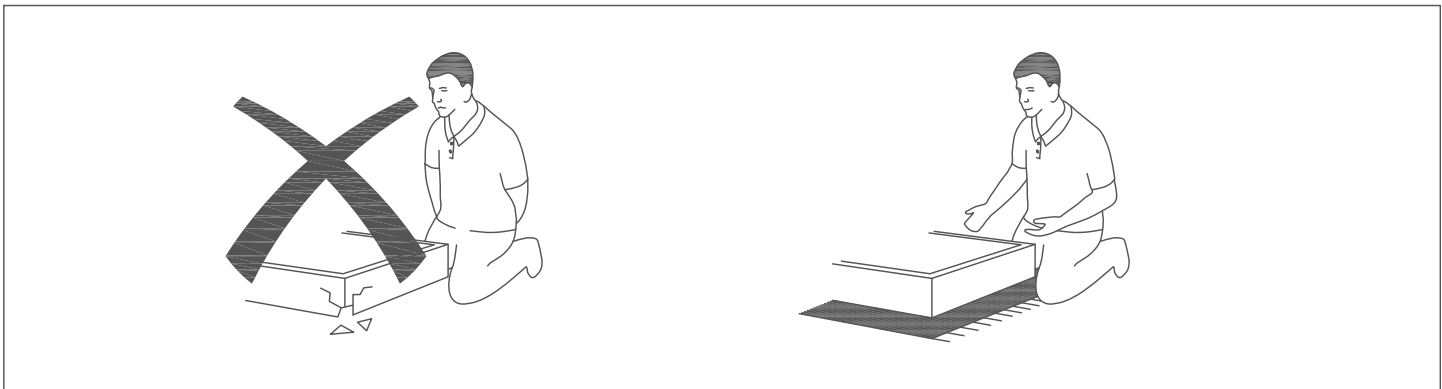
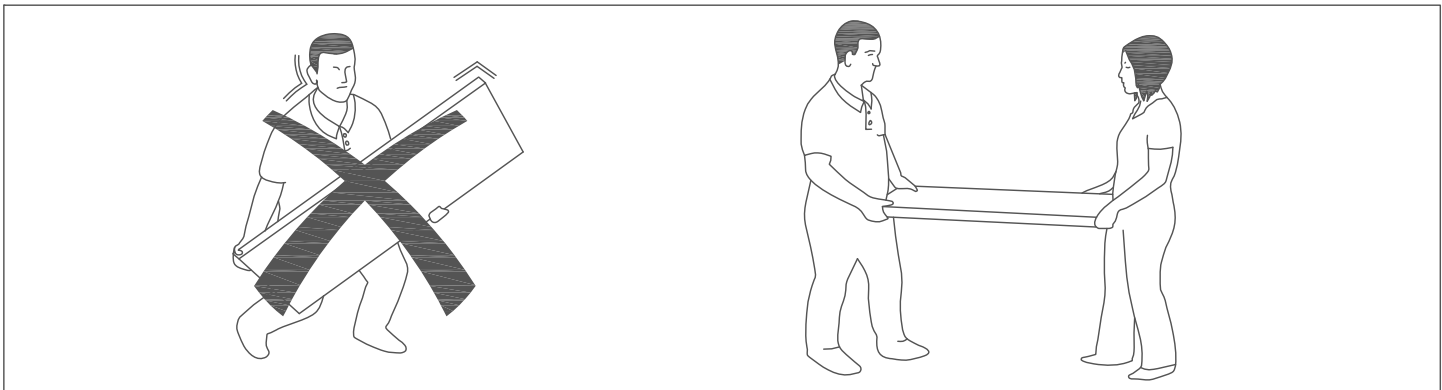
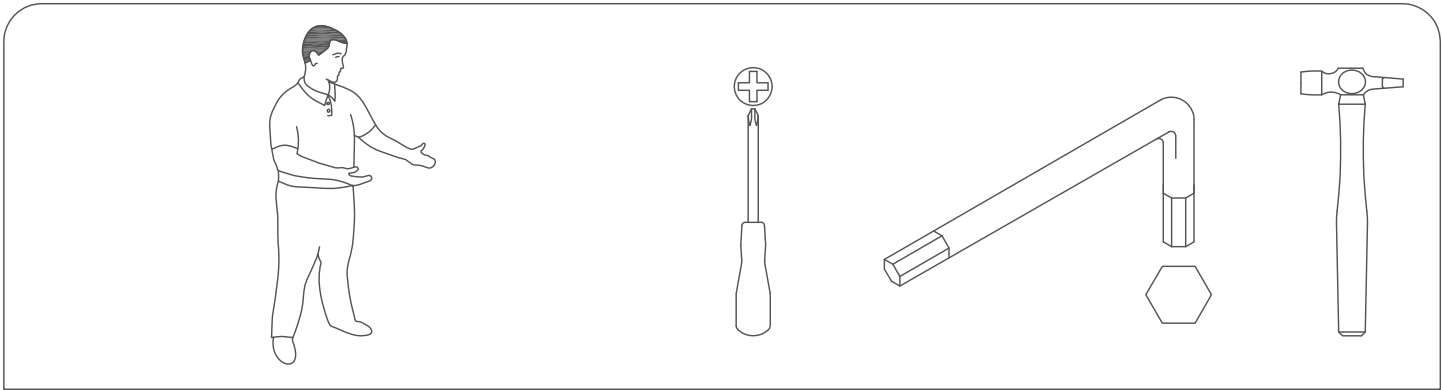

Please check that you have all the fittings

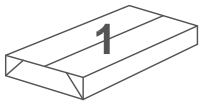

**MSWL
LH LEG**
RM-LGP030

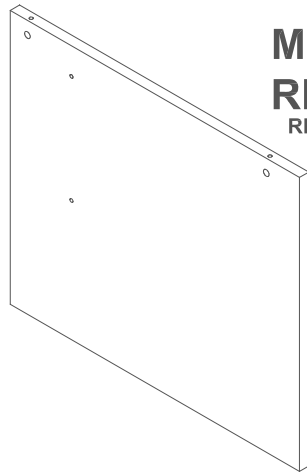
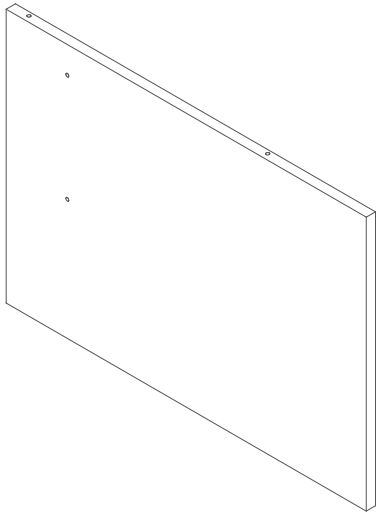

**MSWL
RH LEG**
RM-LGP027



**MS25
BARS**
RM-BARS28

4 Confirmat screw 50mm (Black)
RM-CFM01 

4 Connect Bolt M6x35mm
RM-BLT03 

4 Mini fix bolt B34
RM-BLT07 

1 4mm Allen key
RM-ALK01 

4 Geslpa M8 Blind Rivet Nut
RM-NUT04 

4 Adjustable Foot Dia 25mm
RM-FRL19 

4 Nylon M6x10 Socket
RM-PAR05 

4 Cam 15N
RM-CAM03 

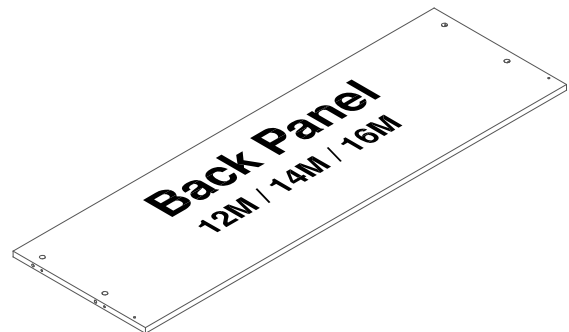
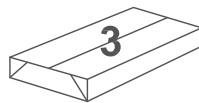
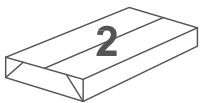

1

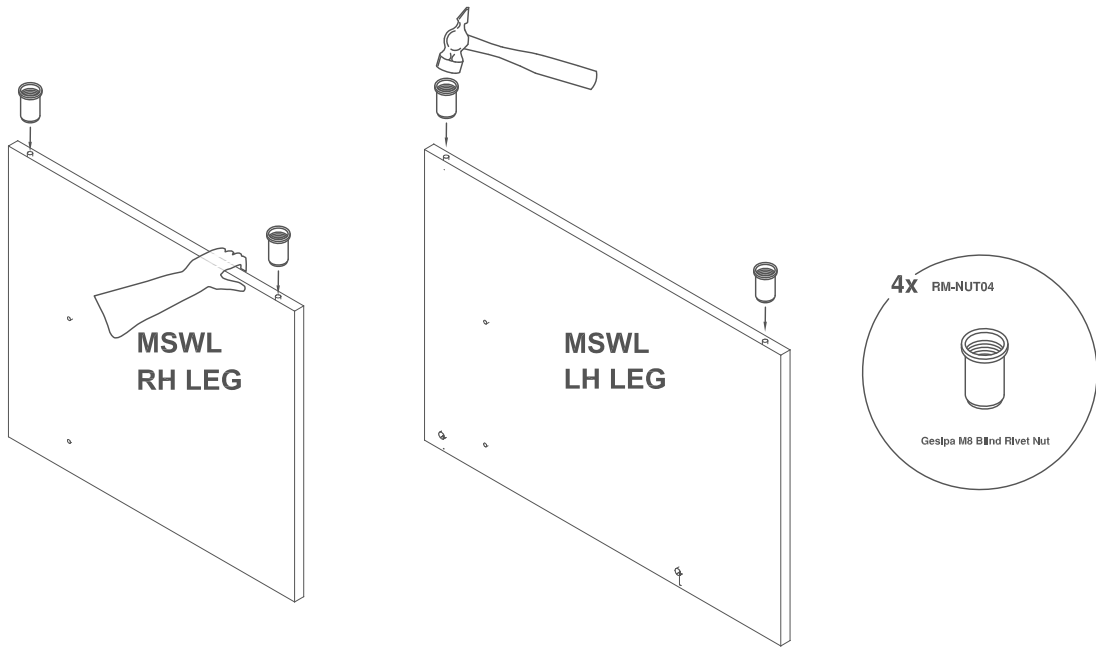

2

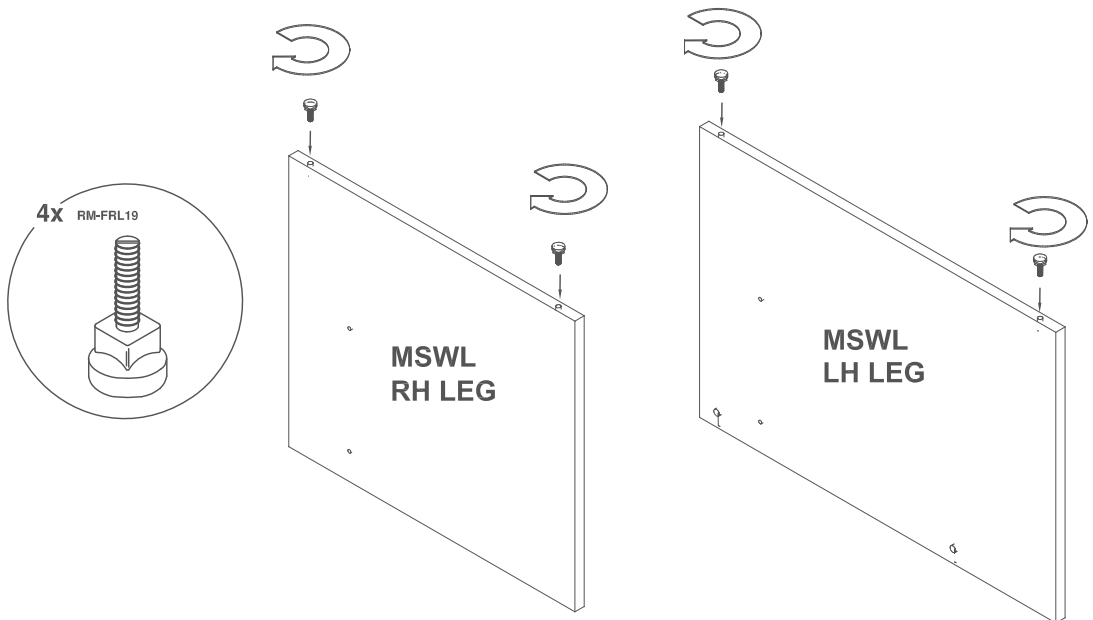

3

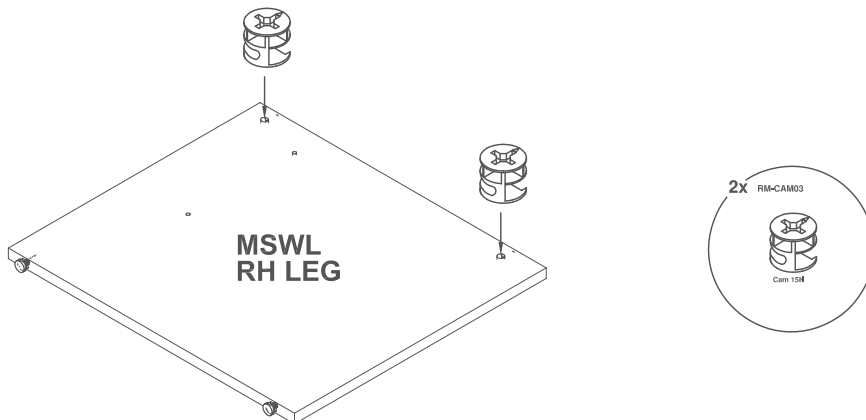

4

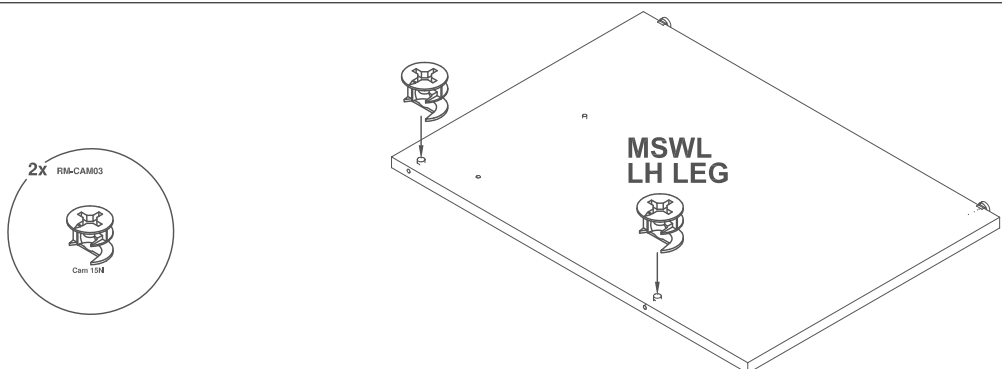

5

4x RM-PAR05

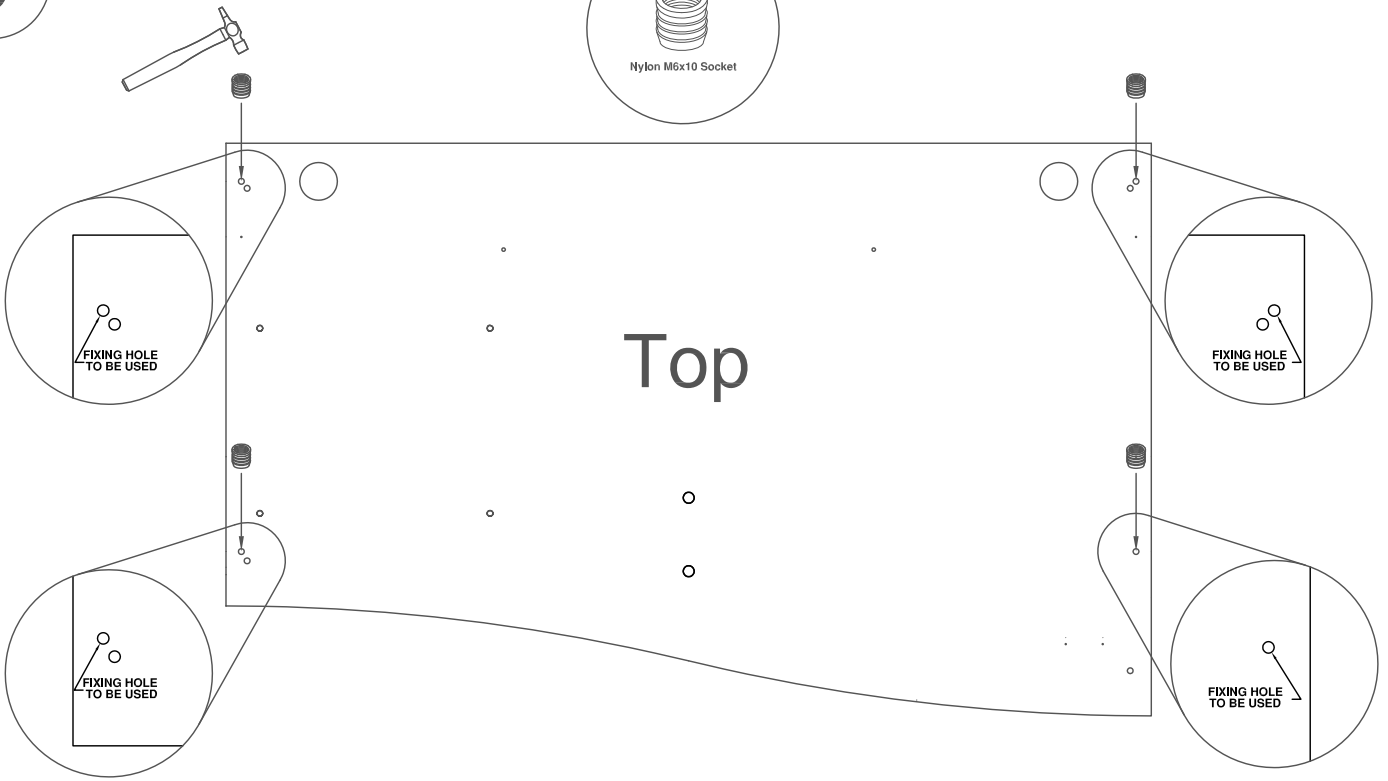

6

4x RM-BLT07



Mini fix bolt B34

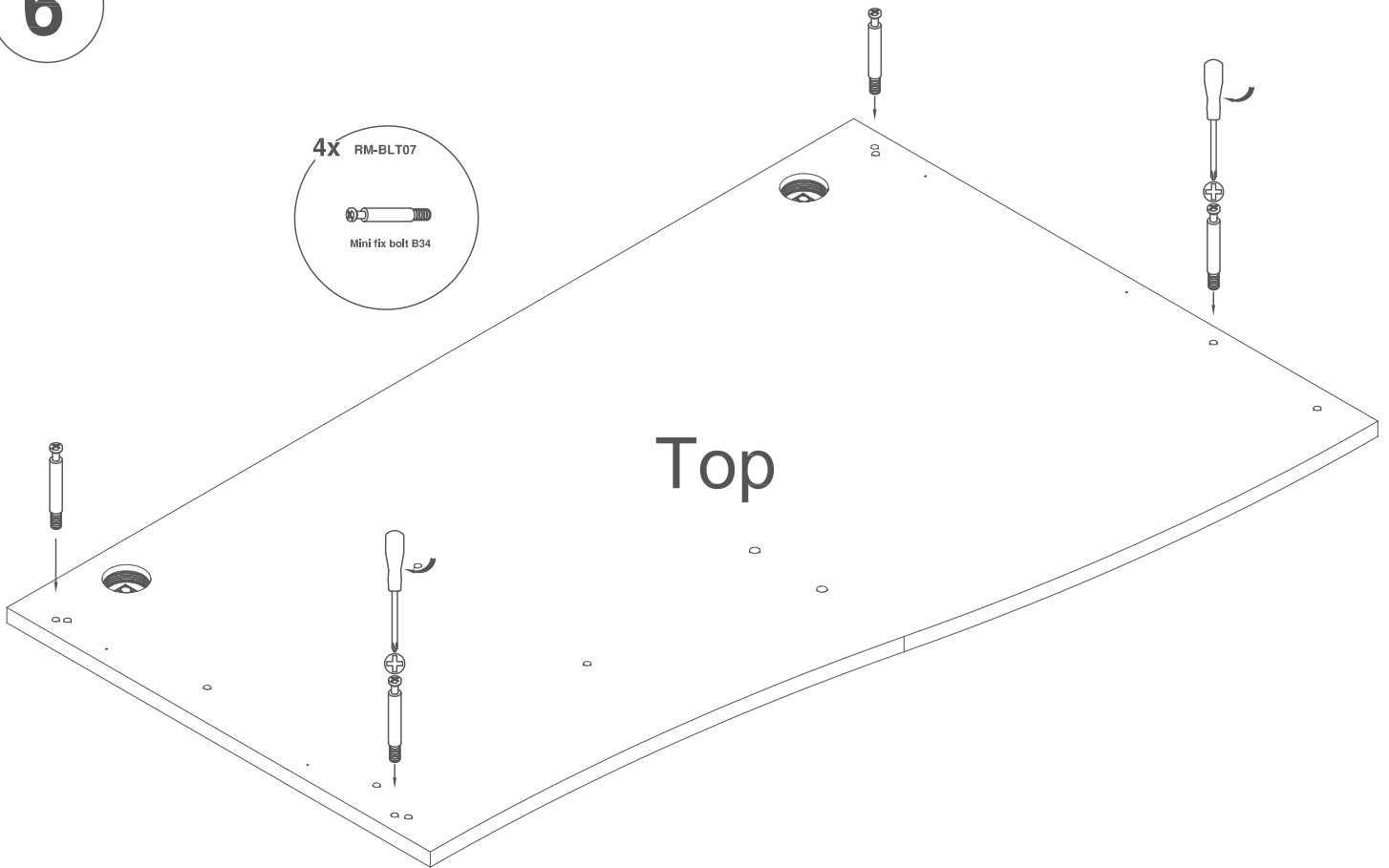

7

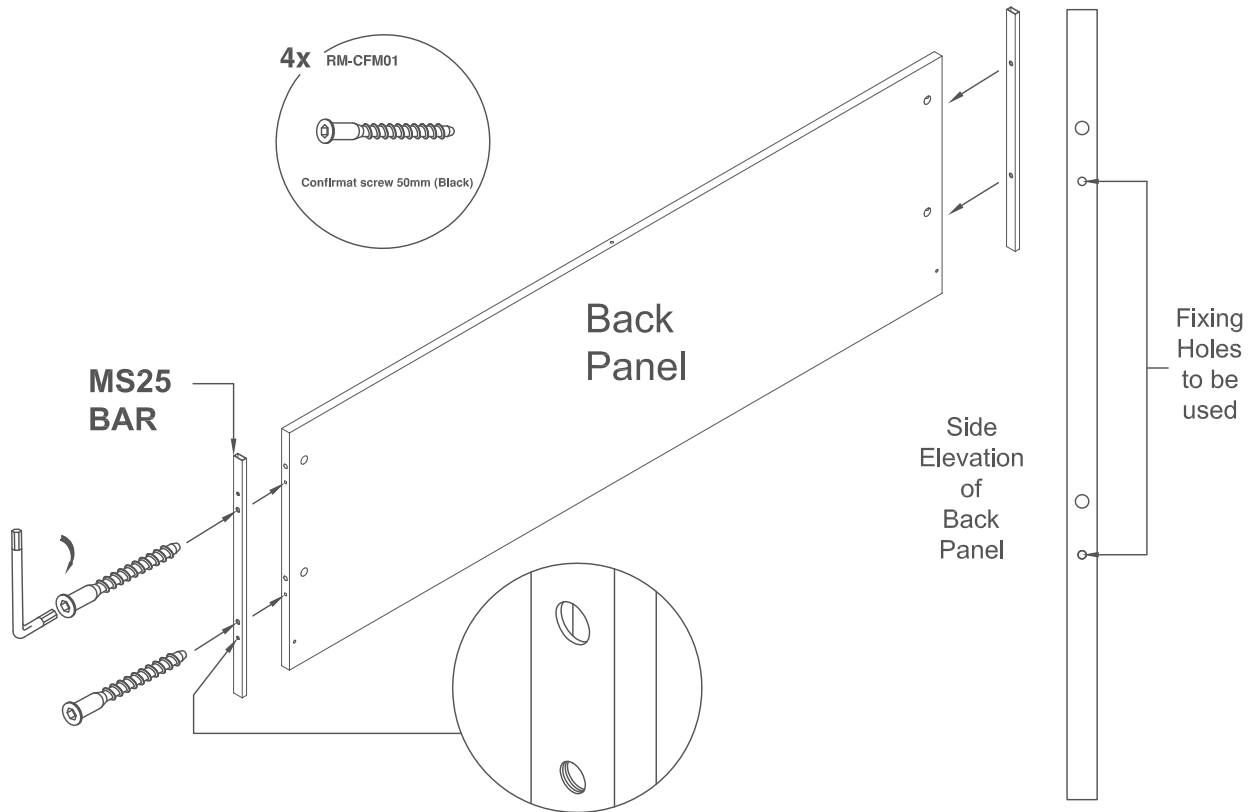

8

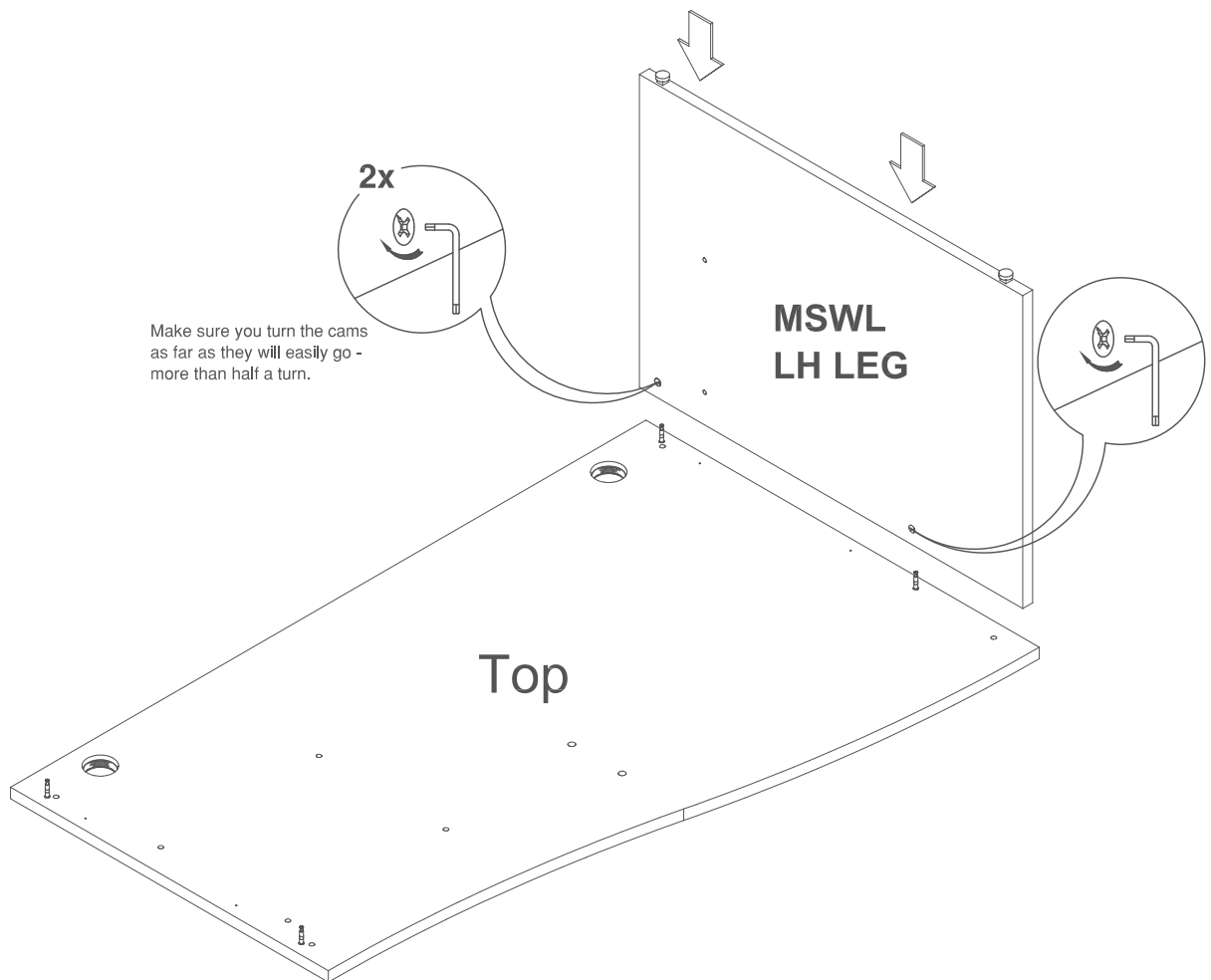

9

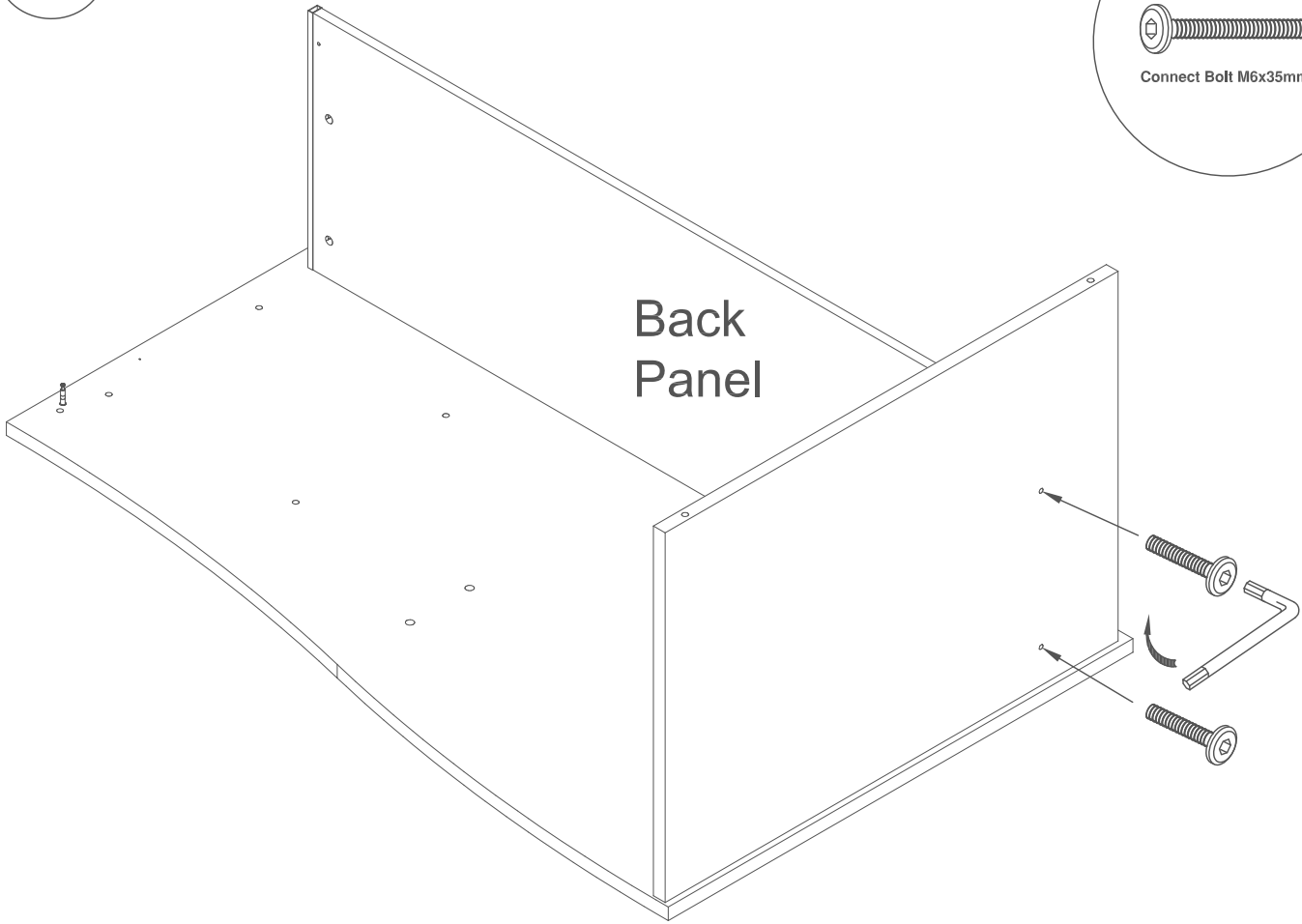
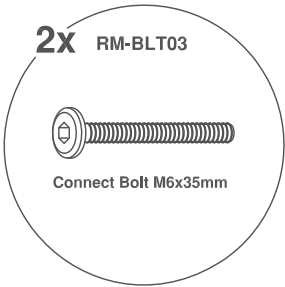

10

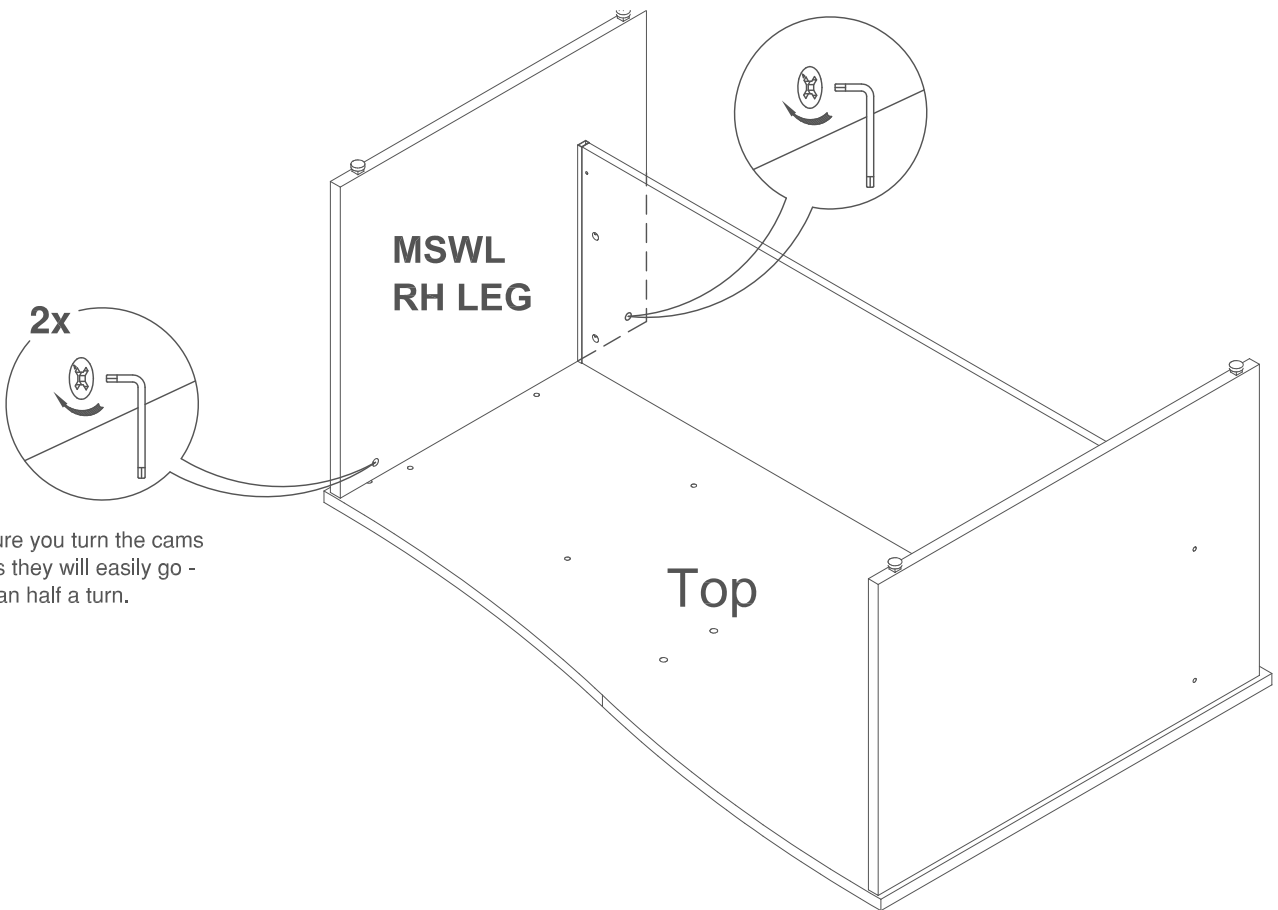

Make sure you turn the cams as far as they will easily go - more than half a turn.

11

2x RM-BLT03



Connect Bolt M6x35mm

