

BAGWS

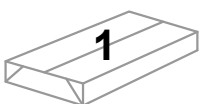

**TOOLS REQUIRED
FOR ASSEMBLY**

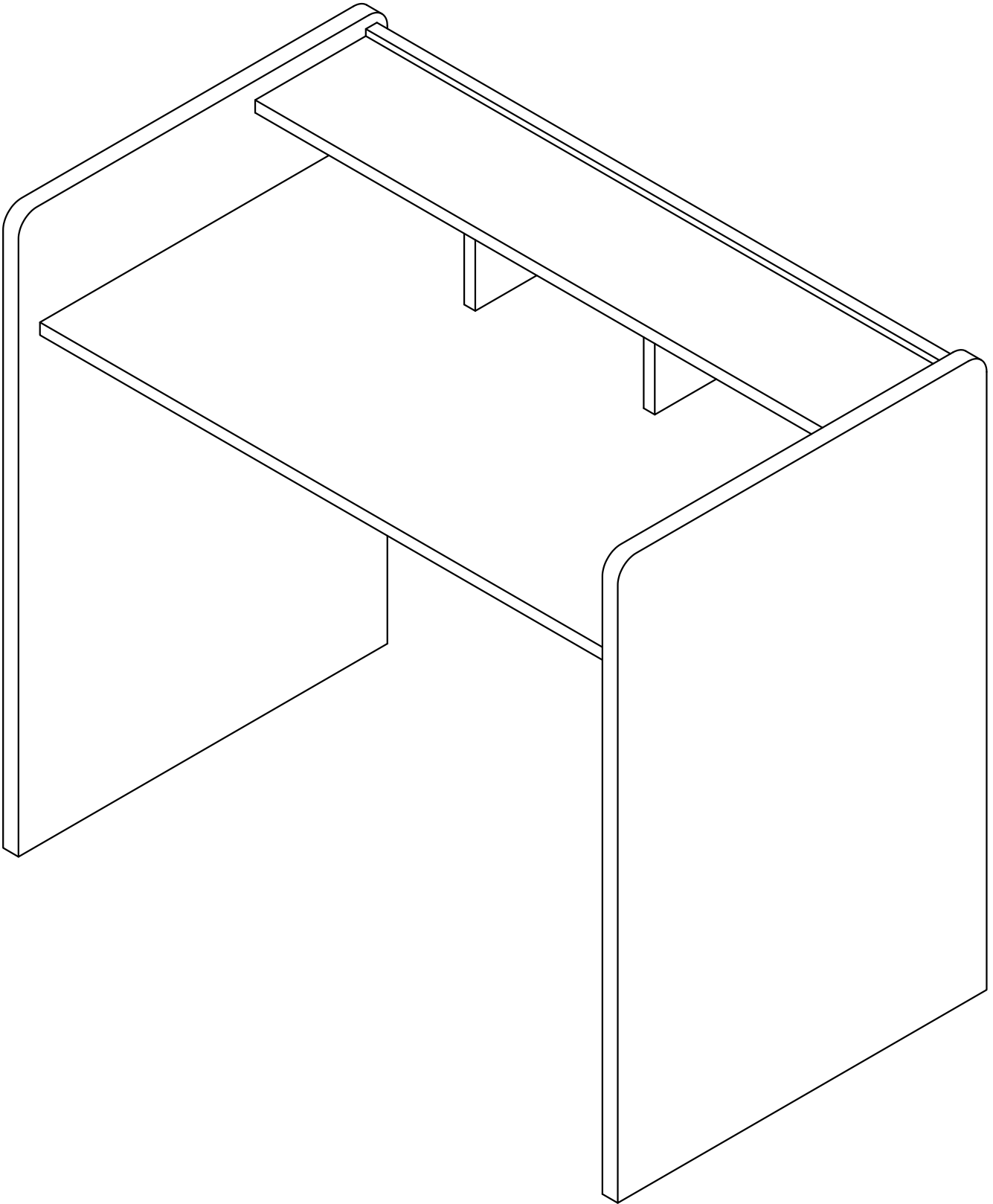
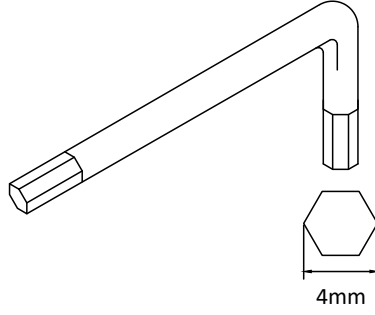
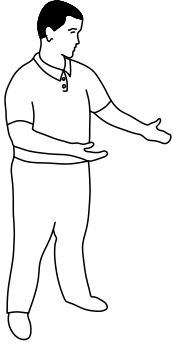

**DONT STRUGGLE
2 MAN LIFT**

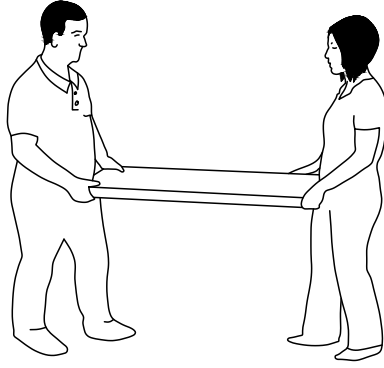

**ALWAYS HANDLE
ITEMS WITH CARE**

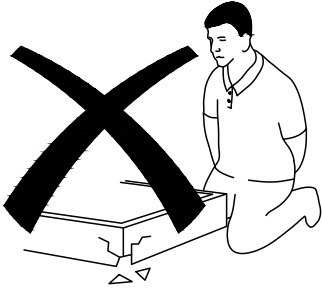

**IF UNSURE CALL
FOR ASSISTANCE**

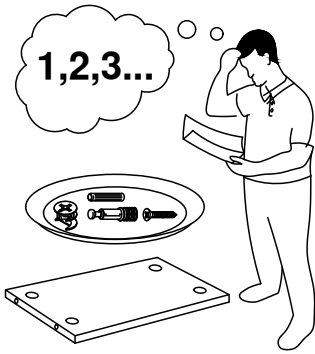

**KEEP FITTINGS AWAY
FROM CHILDREN**

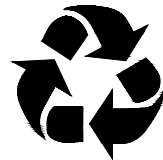
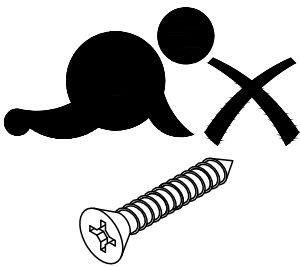



Please check that you have all the panels!

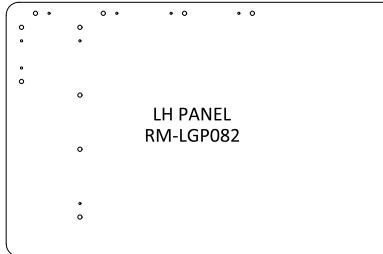
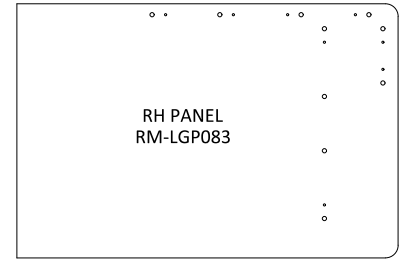
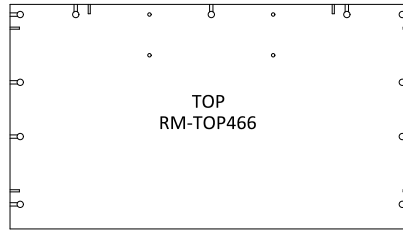
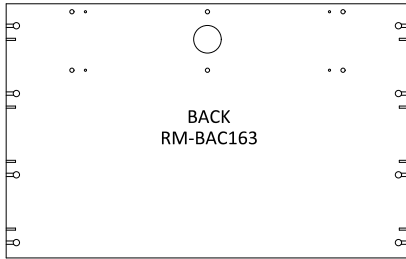

PARTITION RM-PRT021 PARTITION RM-PRT021

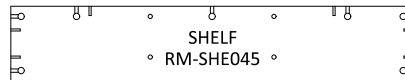
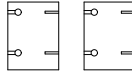

Please check that you have all the hardware!

QUANTITY - 30

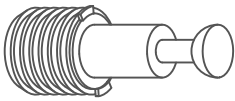

24mm QUICKFIX PIN
RM-BLT06

QUANTITY - 30



15mm QUICKFIX CAM
RM-CAM03

QUANTITY - 4

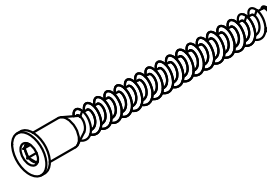

50mm CONFIRMAT SCREW
RM-CFM05

QUANTITY - 20

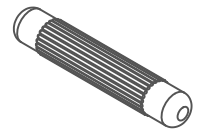

CONNECTOR SCREW
RM-PIN01

Prepare all the panels by inserting the listed fittings into the corresponding holes.

1

Step 1
Insert pins into the pre drilled holes on the LH leg panel.

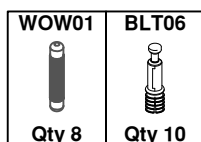
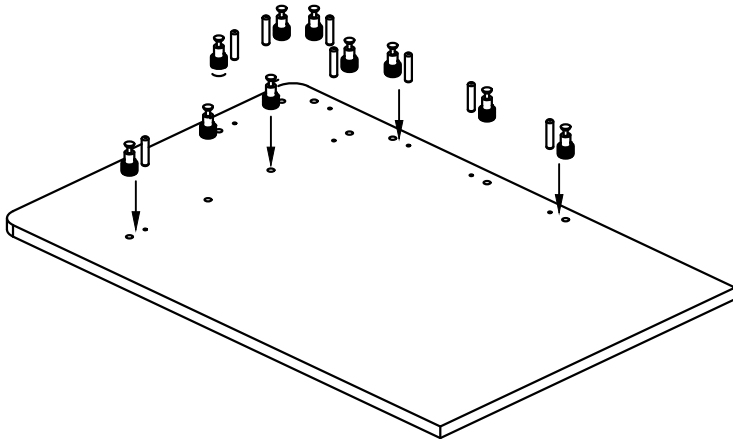

2

Step 2
Insert pins into the pre drilled holes on the RH leg panel.

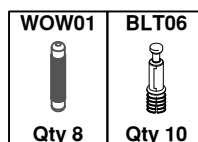
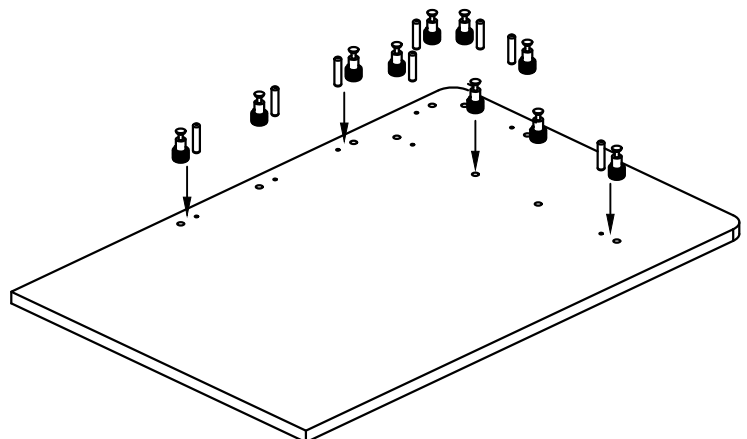

Prepare all the panels by inserting the listed fittings into the corresponding holes.

3

Step 3
Insert pins into the pre drilled holes on the desk top.

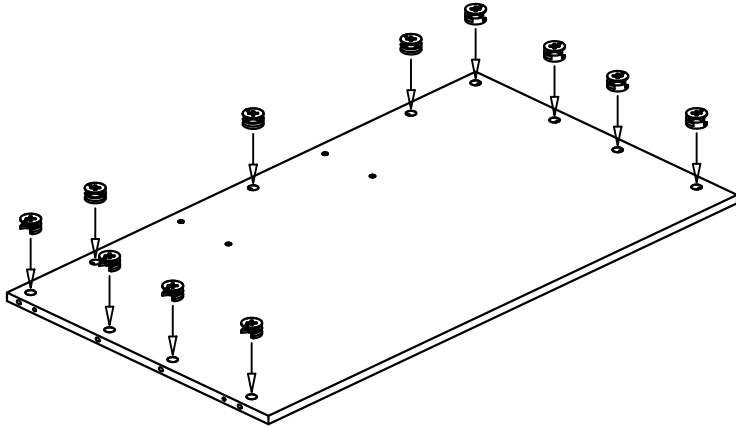

4

Step 4
Insert pins into the pre drilled holes on the back panel.

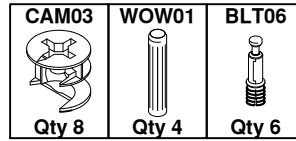
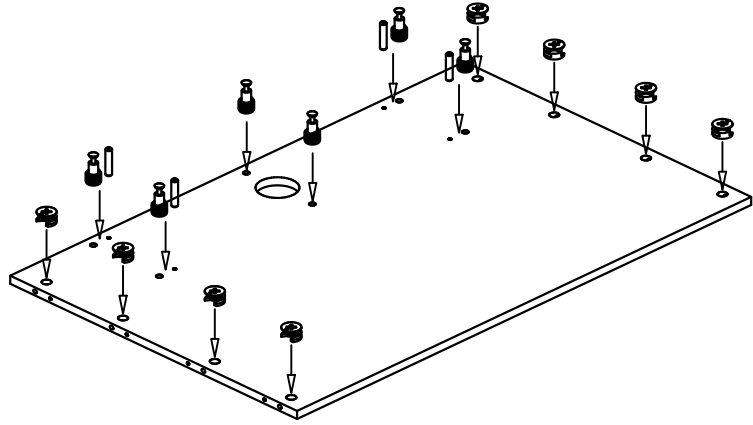

5

Step 5
Insert cams & pins into the pre drilled holes on the top shelf.

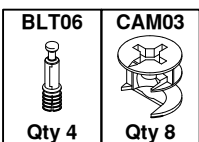
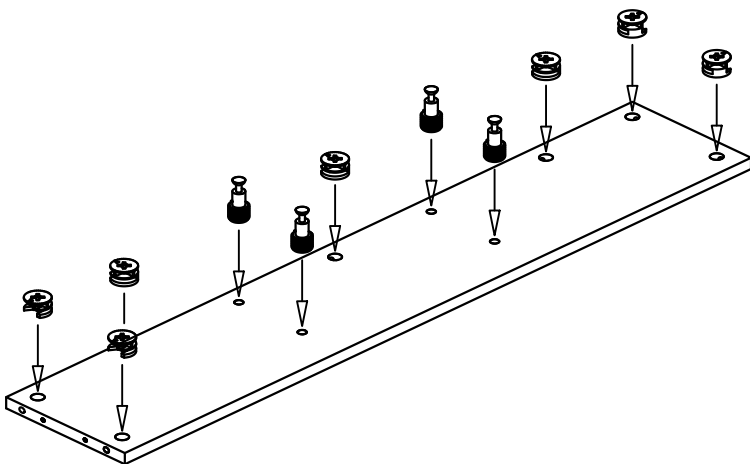

6

Step 4
Insert cams into the pre drilled holes on the partition panels.

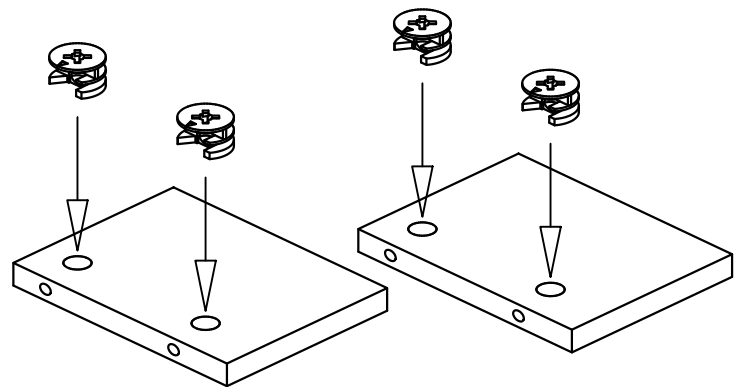

4

7

Step 7
Attach partitions to top shelf panel.

Once the cams and pins are engaged ensure that the cams are fully tightened.

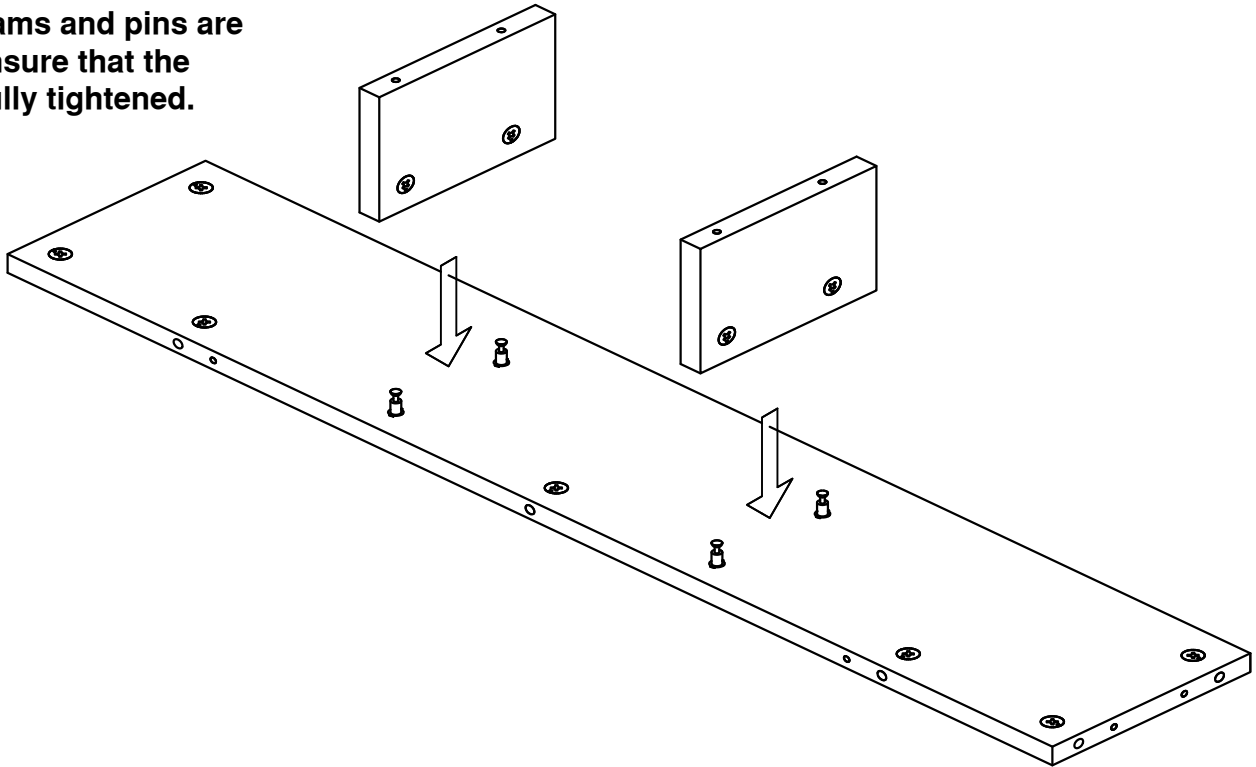

8

Step 8
Attach desktop to partitions using the confirmat screws provided.

a 4mm Allen key is required to insert these screws.

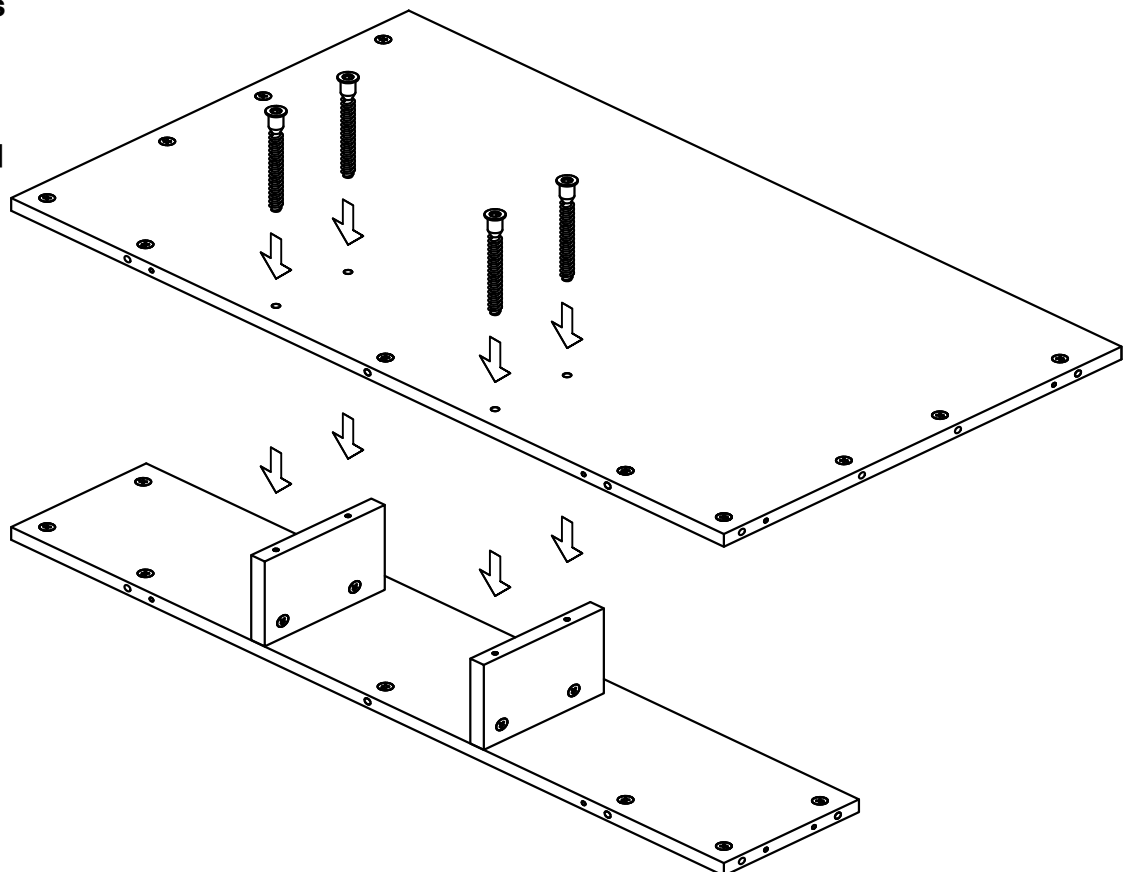

QUANTITY - 4

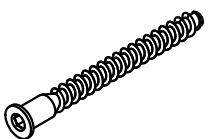

50mm CONFIRMAT SCREW
RM-CFM05

9

Step 9
Attach the unit to back panel.

Once the cams and pins are engaged ensure that the cams are fully tightened.

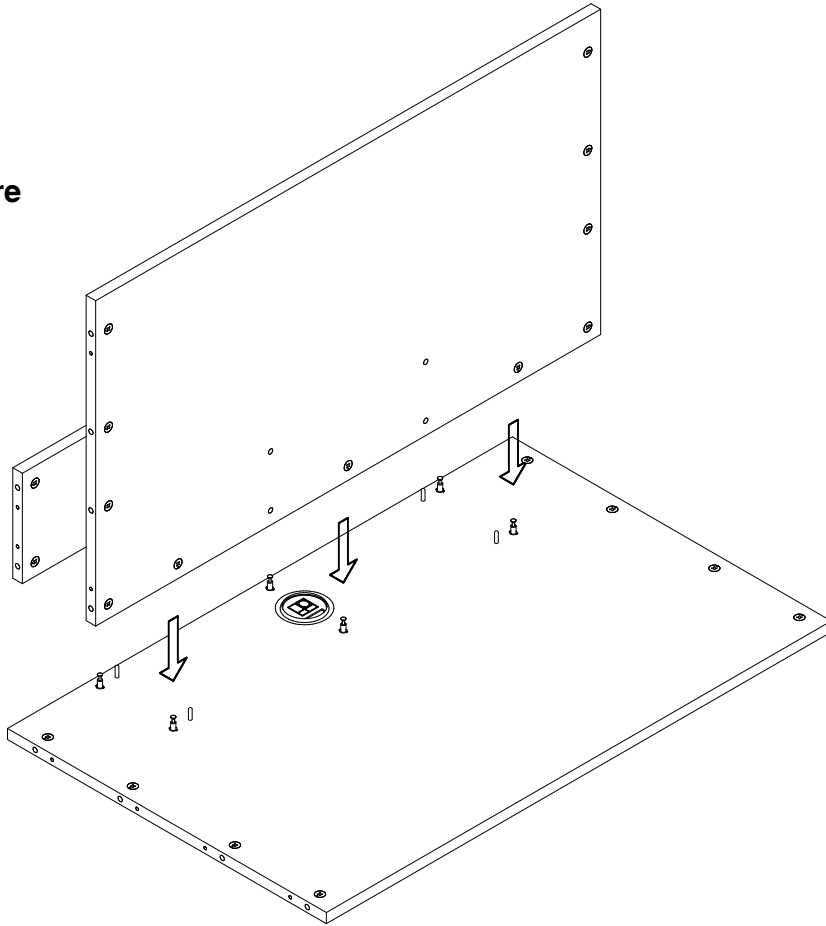

10

Step 10
Attach left and right leg panels.

Once the cams and pins are engaged ensure that the cams are fully tightened.

Once tightened the unit can be lifted into the upright position.

